



OMNI Model 2480

SERVICE MANUAL



ARP INSTRUMENTS, INC.
320 Needham Street
Newton, MA 02164
(617) 965-9700

Document Number 90020000

© February, 1977
ARP INSTRUMENTS, INC.

THE INFORMATION CONTAINED HEREIN IS CONFIDENTIAL AND PROPRIETARY TO ARP INSTRUMENTS, INC. IT IS DISCLOSED TO YOU SOLELY FOR PURPOSES OF INSTRUCTION AS TO OPERATION OF THE EQUIPMENT AND MAINTENANCE AS APPROPRIATE. IT IS NOT TO BE USED BY YOU FOR ANY OTHER PURPOSE, NOR IS IT TO BE DISCLOSED TO OTHERS WITHOUT THE EXPRESS PERMISSION OF ARP INSTRUMENTS, INC.

 OMNI Model 2480

SERVICE MANUAL

TABLE OF CONTENTS

1. INTRODUCTION	
1.1 Product Description	2
1.2 Specifications	2
1.3 Function Description	3
2. THEORY OF OPERATION	5
3. CIRCUIT DESCRIPTIONS	
3.1 Upper Voicing Board	5
3.2 Lower Voicing Board	6
3.3 String Control Board	8
3.4 Synthesizer Control Board	9
3.5 Synthesizer Board	10
3.6 Phaser Board	10
3.7 Power Supply	11
4. ASSEMBLY/DISASSEMBLY	12
5. GENERAL INFORMATION	12
6. CALIBRATIONS	13
7. SCHEMATICS & LAYOUTS	14-33
8. PARTS LIST	34-36

1.1 Product Description

The ARP OMNI offers the unique combination of polyphonic tone sources and the versatility of synthesizer sound modification. Separate string and synthesizer sections allow orchestral and symphonic sounds simultaneously. The total variability of the synthesizer section permits such sounds as brass, piano, and clavinet without single note limitations.

The string and synthesizer sections may be separated by stereo outputs on the rear panel of the OMNI. ARP's now-famous systems interface applies to this product as well. The OMNI can accept external effects or output its own signals to other instruments. The computer-grade switching mechanisms are fast and reliable.

1.2 Specifications

I. Controls

A. String Section

1. Instrument Selection Switches
 - a. Violins (4')
 - b. Violas (8')
 - c. Cellos (8')
 - d. Bass (16')
2. String Envelope Controls
 - a. Attack Time
 - b. Release Time

B. Synthesizer Section

1. Synthesizer Waveform Switches
 - a. 4' and 8'
2. Synthesizer Bass Switches
 - a. 8' and 16'
3. Voltage Controlled Filter
 - a. VCF Freq
 - b. Resonance
 - c. ADSR depth
 - d. LFO depth
 - e. Pedal & Acc. depth
4. LFO Speed Slider
5. Synthesizer Waveforms
 - a. Sawtooth
 - b. Dynamic Pulse
6. ADSR
 - a. Attack Time
 - b. Decay Time
 - c. Sustain Level
 - d. Release Time

C. General Controls

1. Master Volume
2. Bass Volume
3. String/Synthesizer Mix
4. Waveform Enhancement Switch
5. Synthesizer-to-Modulator Switch

II. Outputs

A. Main Outputs

1. High Level Cannon XLR, 1K, 2.5V RMS TYP.
2. Low Level 1/4" phone 10K, .8V RMS TYP.

B. Synthesizer Output

1. Low Level 1/4" phone 10K, .8V RMS TYP.

Can be used simultaneously for discreet stereo effects.

C. Gate Out and Trig Out

1. Gate: Tini D Jack; 0, +10V
2. Trigger: Tini D Jack; 0, +10V pulse, 2 microsec. duration

D. Foot Switch and Foot Pedal

1. Standard ARP accessories

III. Miscellaneous

A. Keyboard

1. 4 octave keyboard, split for bass voices at one and a half octaves from low end

B. Pedals

1. Filter control pedal for foot control of filter brightness

C. Sustain Switch

1. Foot switch works like sustain pedal on piano

D. Materials

1. Aluminum chassis
2. Rigid high-density particle board base
3. Solid walnut endblocks
4. Glass-epoxy circuit boards
5. Industrial-grade electronic components and controls

E. Weight

1. 33 pounds

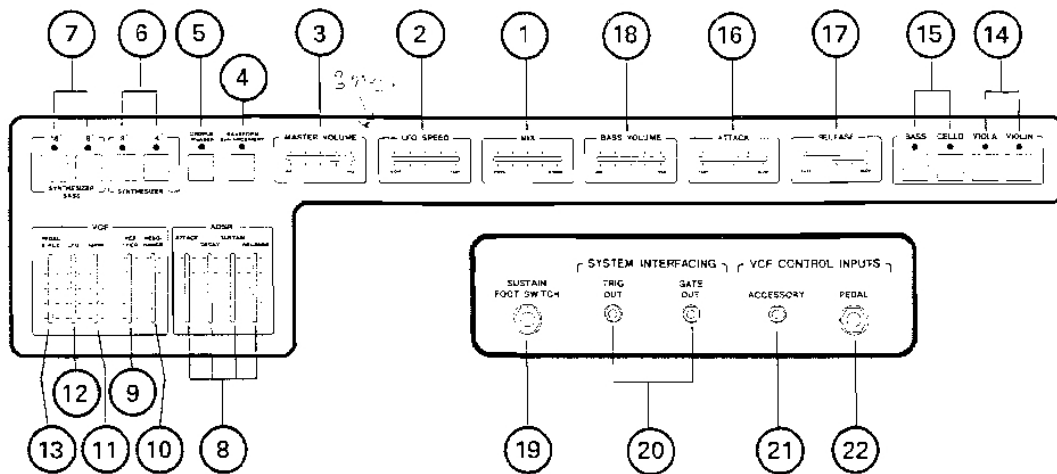

1.3 Function Description

- | | |
|--|---|
| <p>1 <i>Mix Control:</i> Determines the balance of the string voices and the synthesizer voices.</p> <p>2 <i>LFO Speed:</i> Varies the frequency of the Low Frequency Oscillator.</p> <p>3 <i>Master Volume:</i> Determines overall volume of the mixed output.</p> <p>4 <i>Waveform Enhancement:</i> Alters waveforms produced by the Omni to a hollow like (square) sound.</p> <p>5 <i>Chorus Phaser:</i> Routes the synthesizer output through the string section's phase shifters and reduces the phase shifters speed. (When depressed the synthesizer output appears on the string output as well.)</p> <p>6 <i>Synthesizer 8', 4':</i> Selects the synthesizer section's pitch ranges.</p> <p>7 <i>Synthesizer Bass 8', 16':</i> Selects the synthesizer's bass voices and disables synthesizer 8' and 4' voices in bass range (first octave and a half).</p> <p>8 <i>ADSR Envelope Generator:</i> Determines the attack and decay characteristics of the synthesizer section.</p> <p>9 <i>VCF Frequency Slider:</i> Sets the VCF's initial frequency cutoff point.</p> <p>10 <i>VCF Resonance Slider:</i> Sets degree of VCF resonance ("wow" effect).</p> | <p>11 <i>VCF ADSR Slider:</i> Determines brightness of synthesizer section.</p> <p>12 <i>VCF LFO Slider:</i> Determines depth of tremelo.</p> <p>13 <i>VCF Pedal and Accessory Slider:</i> Determines range of external pedal or accessory.</p> <p>14 <i>Violin and Viola:</i> Selects the string pitch ranges.</p> <p>15 <i>Bass, Cello:</i> Selects bass string pitch ranges (low note priority, lowest octave and a half only).</p> <p>16 <i>Attack:</i> Determines attack of string section.</p> <p>17 <i>Release:</i> Determines the final release time of string section (also effects synthesizer release).</p> <p>18 <i>Bass Volume:</i> Determines bass volume for synthesizer 16', 8' and bass and cello.</p> <p>19 <i>Sustain Foot Switch:</i> Sustains all notes when foot switch is depressed (regardless of release slider settings).</p> <p>20 <i>Gate and Trigger Output Jacks:</i> Used to connect to other synthesizers.</p> <p>21 <i>Accessory Jack:</i> Connected to VCF control input so that VCF may be controlled by external sources such as the ARP Sequencer or Sample and Hold outputs, etc. for special effects.</p> <p>22 <i>Pedal Jack:</i> Used to connect VCF filter pedal.</p> |
|--|---|

SIMPLIFIED OMNI BLOCK DIAGRAM

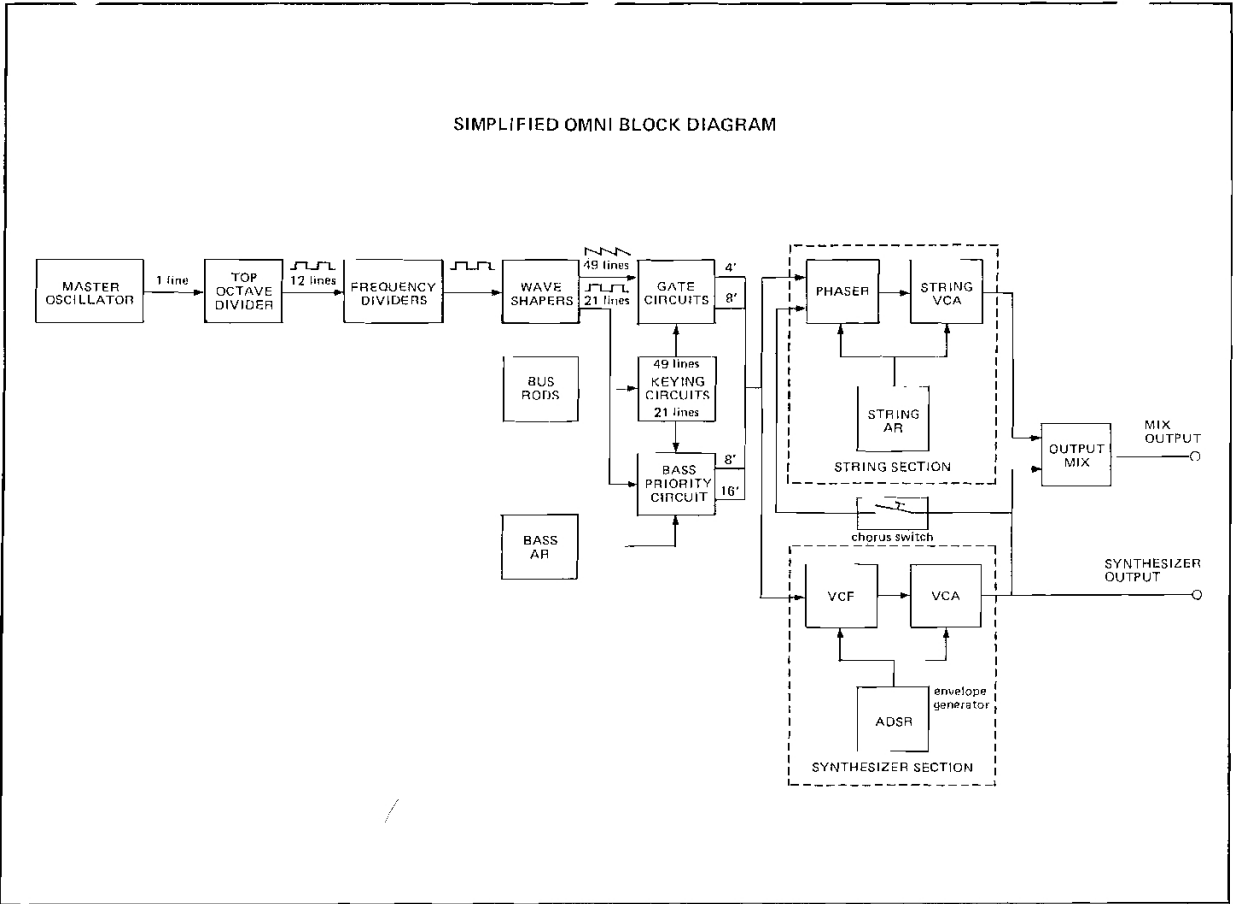

SECTION 2 THEORY OF OPERATION

The OMNI's tone generator circuitry consists of a master oscillator at 500 kHz., which drives a large scale integrated circuit top octave divider. The top octave divider produces the highest twelve tones in the instrument. Frequency dividers derive the remaining pitches from the top octave divider. The squarewave outputs of each divider are waveshaped to a sawtooth form (the waveform enhancement alters the waveshape to a differentiated squarewave).

The tones from the waveform generator are fed to transistor gating arrays which route the signal to the string section and the synthesizer section. The transistor gating arrays are 'keyed' on by an RC circuit connected to each key. The release time of each key (how long the note remains after a key release) is determined by the release capacitor on each gating input.

The outputs of all the gating arrays are summed and routed to the string section and the synthesizer section.

The string section consists of three parallel phase shifters which modulate the sawtooth waveforms from the gating circuits. The phaser outputs are processed through a Voltage Controlled Amplifier to control the attack characteristics. (The release is controlled by the release capacitor on each gating circuit).

The synthesizer section processes the gate outputs of the arrays through a Voltage Controlled Filter and Voltage Controlled Amplifier, both of which are controlled by an ADSR Envelope Generator. The synthesizer output can be routed through the string section phasers when the Chorus Phaser Switch is selected. The speed of the phasers is reduced when the Chorus Phaser is selected. The outputs of the string section and the synthesizer section are summed together in the Mix Circuitry and routed to the output of the instrument. A separate synthesizer output is provided for stereo effects.

SECTION 3 CIRCUIT DESCRIPTIONS

3.1 Upper Voicing Board

GENERAL: The Upper Voicing Board contains the Master Oscillator, Top Octave Divider I.C., Frequency Dividers, Wave Shaping for tones C7 through C4, Keying Circuits for keys 21 through 49 and six of the ten Gate Circuit I.C.'s. The remaining Waveshaping, Keying Circuits and Gate I.C.'s are located on the Lower Voicing Board. (Note: There are two schematics for this board.)

3.1.1 MASTER OSCILLATOR AND TOP OCTAVE DIVIDER

(Refer to Upper Voicing Schematic, sheet 1 of 2.)

L1 and Q1 produce a 0 to -15 volt sine wave at approximately 500KHz. The frequency of the oscillator can be varied by adjusting the core of the coil (externally accessible). Z1 buffers and squares the waveform from the Master Oscillator and supplies it to the Top Octave Divider, Z2. Z2 is a LSI (Large Scale Integrated Circuit) divider which produces the highest octave (square waves) of the instrument (C6-C7).

3.1.2 DIVIDER AND WAVE SHAPING CIRCUITS

(Refer to Upper Voicing Schematic, sheet 1 of 2.)

The square wave outputs from Z2 are supplied to the clock inputs of CD4520BE divider chips (Z3-Z7) which produce square waves for each key. The square wave outputs of the CD4520BE's are buffered by inverters Z9-Z16.

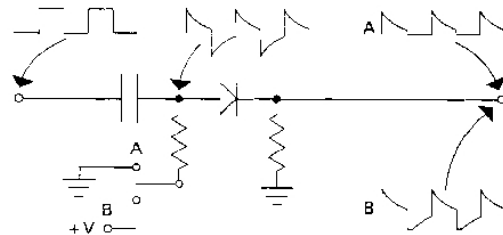

Waveform converter and waveform enhancement

The square waves from inverters Z9-Z13 and from Z2 are differentiated by capacitors C17-C49 (values are selected for each frequency). CR1 through CR41 clip the negative portion of the differentiated square wave resulting in sawtooth shaped waveforms. By altering

the DC bias (P6-7, Waveform Control Bus) some of the negative portion of the differentiated waveform is permitted to pass through diodes CR1-41 when the Waveform Enhancement is selected resulting in a "hollow" type sound.

3.1.3 KEYING CIRCUITS

(Refer to Upper Voicing Schematic, sheet 2 of 2.)

Each key contact (P7-5, P7-4, P7-3, etc.) is connected to a 22uf electrolytic capacitor through a 470ohm resistor. The capacitor is normally charged to 0 volts (The negative side of the capacitor is at -15 volts.). When a key is depressed, the capacitor is discharged to -15 volts. The time the capacitor takes to recharge to 0 volts sets the release time of each note and can be varied by the release slider (R31) on the String Control Board. The key voltages produced for each key (indicated by letters KV) are supplied to two gate circuits; one for 8', one for 4'.

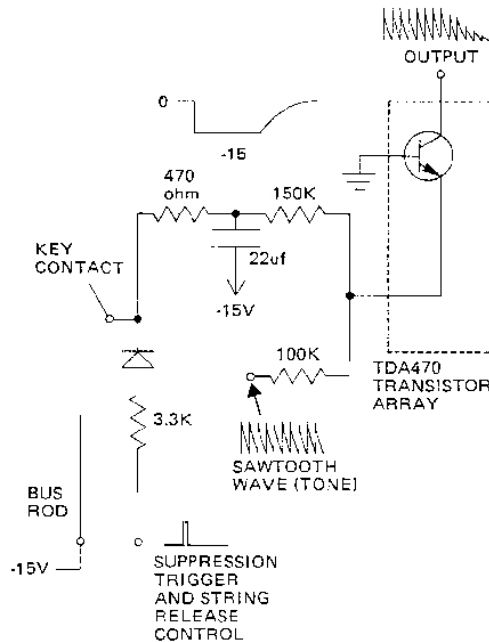

Keying and Gating circuit

3.1.4 GATE CIRCUITS

(Refer to Upper Voicing Schematic, sheet 2 of 2.)

There are a total of 10 gate transistor arrays (TDA470) in the OMNI which gate signals from the tone generator sections to the output section. Each Gate has ten transistors (on a common substrate) with common collectors and bases. The emitters serve

as the inputs to the devices. Five of the arrays are used for 4' pitches and five for 8' pitches. Therefore, one key controls two gate chips at a time (4' and 8').

The Upper Voicing Board contains three 4' gate arrays and three 8' arrays; the remaining arrays are on the Lower Voicing Board. All of the arrays have the base pin (7) grounded. Each of the sawtooth waveforms are supplied to an emitter through a 100Kohm resistor (e.g. Tone G 4 is supplied through resistor pack Z30 pins 5 and 6 to pin 12 of Z31.). Keying voltages (denoted by KV) are supplied to the emitters also through 150Kohm resistors (e.g. KV21). As long as the keying voltage is at or near 0 volts, the transistor remains off. When a key is depressed, the keying voltage drops to -15 volts, which turns on the transistor in the array and permits the signal to pass to the collector of the array and out to the mixing circuitry (e.g. from pin 12 of Z31 to pin 14).

3.2 Lower Voicing Board

GENERAL: The Lower Voicing Board contains the Bass Low Note Priority circuitry, 4' and 8' Mixing circuitry, Gate Sensing circuitry, Suppression Trigger circuitry, 8' and 16' Bass circuitry, Keying circuits for keys 1 through 20, Gate circuits for tones C2 through G3, and Waveshaping for tones C2 through G3.

3.2.1 WAVESHAPING, KEYING AND GATE CIRCUITS

(Refer to Lower Voicing Schematic, sheet 1 of 3.)

The Waveshaping, Gating and Keying circuits on this board are a continuation of the circuits on the Upper Voicing Board. See sections 3.1.2, 3.1.3 and 3.1.4 for detailed descriptions.

3.2.2 BASS LOW NOTE PRIORITY CIRCUIT

(Refer to Lower Voicing Schematic, sheet 2 of 3.)

The 8' and 16' Bass section of the OMNI is single note, low note priority. The Bass section covers the lowest octave and a half of the keyboard (Keys 1 through 20). The release time of the Bass section is fixed, the release control on the front panel has no control over the Bass section. Unlike the 4' and 8' polyphonic tones, the Bass Priority Circuit receives and generates only square waves.

The function of the Bass Low Note Priority circuit is to route the square wave of the lowest note depressed (only) in the Bass section to the 8' and 16' Bass Waveshaping circuits (through CR41-60) for processing.

The Bass Waveshaping circuits are monophonic; they may only accept one waveform at a time.

Square wave tones C2-G3 are routed from the Upper Voicing Board frequency dividers to one input of a three input nor gate for each key (Z33-Z39). The outputs of these nor gates are inverted square waves only when the other two inputs are a logic 0 (e.g. Z33B pin 6 is a square wave only if pin 4 and pin 3 are at logic 0.).

NOTE: All logic gates in the Bass Low Note Priority section are COSMOS (Complimentary Symmetry Metal Oxide Semiconductor) devices. For this particular application, they are operated between ground and -15 volts. Therefore, a logic 1 is any voltage between ground and -7.5 volts, logic 0 is any voltage between -7.5 volts and -15 volts.

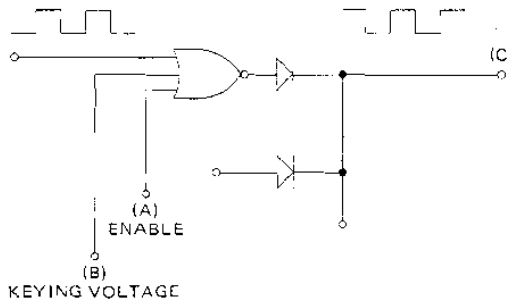

The output (C) of the NOR gate will be a square wave only when the Enable (A) input is a logic 0 (-15V) and when the Keying voltage is less than -7.5V.

The "enable" input of the three input nor gates (e.g. Z33B, pin 3) will always be a logic 0 (-15 volts) provided no keys are depressed to the left of the circuit under examination.

When a key is depressed, -15 volts from the bus rod discharges a 1uf sustain capacitor through keying transistors (Q1-Q20). (e.g. Key 2, P1-12 discharges C42 through R7, Q2 and CR63 to -15 volts on key depression.) When a key is released, the voltage on the capacitor is allowed to charge back to 0 volts through a 3.3Mohm resistor (e.g. R5). This keying voltage is routed to an input of the three input nor gates (e.g. Z33B, pin 4). Thus the keying voltage permits the square wave to be transmitted from the input of the three input nor gate to the output provided that A) the keying voltage is less than -7.5 volts and B) the enable input is a logic 0 (indicating no lower keys are being played).

The keying voltage is also processed through a COSMOS inverter (Z45-Z47) and a nor gate

(Z33-Z47) to transmit serially a logic 1 state to all keys higher than the one depressed.

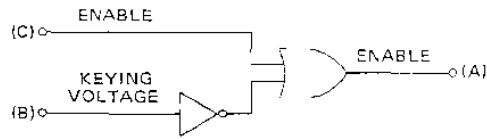

Enable (A) is a logic 0 only when Enable (C) and the Keying voltage is less than -7.5V (logic 0).

The release time (decay time after keys are released) is fixed at about 2.5 seconds, however, an additional charge path is provided through Q1-20 for those keys not depressed to shorten the release time. When no keys are depressed, Q1-20 are off. The base voltage of Q1-20 is always held a full diode drop above the keying (bus rod) voltage in the reference generator.

3.2.3 BASS KEYING VOLTAGE

(Refer to Lower Voicing Schematic, sheet 3 of 3.)

The T point of the Bass Keying Reference Generator supplies a voltage to the base of Q1-20 of the Bass Low Note Priority Circuit which is at least three diode drops higher than the keying voltage supplied to the Lower keyboard bus rod (P1-14). The diode drops are created using CR114, Q30 and CR113. This insures that Q1-20 will be biased ON regardless of the bus voltage which decreases as more keys are depressed.

3.2.4 GATE DETECTOR CIRCUITS

(Refer to Lower Voicing Schematic, sheet 3 of 3.)

There are two bus rods in the OMNI, one for the lowest 20 keys, one for the upper 29 keys. Splitting the bus rod in this manner permits a bass envelope (Bass AR) to be developed separately from the higher keys.

CR107 (Upper Bass Gate Detector) is the voltage source for the upper bus rod. -15 volts is supplied through CR107 and R130 to the bus rod. When a key is depressed, comparator Z52B switches from -15 volts to ground (Gate). The current drawn through R130 on key depression results in a voltage drop across R130. The voltage change across R130 is differentiated by C86 so that the output of comparator Z52A momentarily switches from +15 volts to -15 volts and back again (10ms. typical duration, longer for multi-key depressions). This

pulse is used for triggering the Envelope Generator (ADSR) and to discharge sustain capacitors on keys not being played.

3.2.5 8' AND 16' BASS WAVESHAPING

(Refer to Lower Voicing Schematic, sheet 3 of 3.)

The single square wave from the Bass Low Note Priority Circuit (U2) is buffered through Z51A and gated through a "VCA" made up of CR105, R112 and C77. The Bass AR voltage (J11-8) is 0 volts when no keys are depressed and drops to -15 volts when a key is depressed. This voltage sets the bias of CR105 to clip the square wave on the output of Z51A. As the AR voltage drops from ground, the amplitude of the square wave increases. C77 AC couples the square wave to an emitter follower (Q21) and the 8' Bass Waveshaping (R116, C78, R117, C79, Q22). The base and emitter of Q21 are biased the same (+7V). This means that only the differentiated rising edge of the square wave will bias Q21 on, thus clipping off the falling edge of the square wave. The sawtooth waveform on the emitter of Q21 is divided down by R114 and R174 and used for the synthesizer Bass signal. The sawtooth is also altered and resonated by Q22 and used for the string bass signal. The 16' Bass Waveshaping accepts the buffered 8' square wave from Z51A and divides the frequency in half (Z49). CR106, R119 and C80 are the "VCA" for the 16' Bass circuit. Buffer and filtering are provided as with the 8' Bass (Q23 and Q24).

3.2.6 WAVEFORM CONTROL

(Refer to Lower Voicing Schematic, sheet 3 of 3.)

The Waveform Control sets the bias point of the clipping diodes in the Waveshaping circuits for each key. When the output of Z53 is 0 volts, sawtooth waveforms are produced. When the output of Z53 is -15 volts, the "hollow" sound is produced. J11-9 is ground when the Waveform Enhancement switch is off, +15 volts when the switch is on. CR107 provides a little extra voltage to the output when the input is +15 volts since the op amp cannot supply more than about +13.5 volts by itself.

NOTE: The CA339E (Z52) is an open collector output comparator. When the inverting input (-) is more negative in voltage than the noninverting (+) input, the output is open; the voltage is determined by external "pull up" resistor circuits or networks. This device is not a standard op amp; it is a specialized comparator (no feedback).

The Lower Bus Trigger Detector circuit and Lower Bus Gate Detector circuit are equivalent to the Upper Bus circuitry. CR112 is the lower bus voltage source, R150 creates the voltage difference for the lower bus trigger on key depression.

The Upper and Lower Bus Triggers are combined on the base of Q27 and supplied via Q26 to the pulse drive circuit and sustain bus. The sustain bus is the common discharge path for the keying capacitors for each key. The trigger pulse rapidly discharges any keying capacitor not being played to prevent notes from running together when the release slider is at maximum.

3.2.7 4' AND 8' SUM

(Refer to Lower Voicing Schematic, sheet 3 of 3.)

The outputs of the five 4' and 8' gating transistor arrays (TDA470) are summed in the 4' and 8' Sum circuits. Formant filtering is provided to voice the instrument. CR101, CR102, CR103 and CR104 are blocking diodes which disable the outputs of the bass section (first 20 notes) when the 8' or 16' Synthesizer Bass switches are on. Z48 supplies +15 volts when the Bass controls are on which reverse biases the blocking diodes.

The 4' Poly Sum (J11-16) and 8' Poly Sum (J11-2) are routed to the String and Synthesizer sections of the OMNI.

3.3 String Control Board

GENERAL: The String Control Board contains the String AR Envelope Generator, AR Suppression, AR Squelch and String Voice Selection circuits. The AR Suppression forces the AR to release fully between key depressions, yielding the proper string attack times. The AR Squelch forces the release time of the AR to be the same as the release time of all the key capacitors by tracking the audio level from the String Voice Selection.

3.3.1 STRING VOICE SELECTION

(Refer to String Control Board Schematic.)

Z1 is a COSMOS Quad Switch which selects the four pitch ranges: 4' and 8' polyphonic and 8' and 16' bass. Z3A sums the four pitch ranges and routes them to the Phaser Board. Z2 (pins 3, 4 and 5) permits the Synthesizer section to be summed with the String signals and for processing through the Phaser Board. Pins 1, 2 and 13 disable the String AR when no string voices are selected.

3.3.2 STRING AR AND AR SUPPRESSION

(Refer to String Control Board Schematic)

The String AR Envelope Generator produces a control voltage which controls the gain of the String VCA on the Synthesizer Control Board. C15 is the integrating capacitor and is normally at 0 volts when no keys are depressed. When a key is depressed, the gate signal on Z4A pin 6 changes from -15 volts to 0 volts. Comparator Z4A's output changes to -15 volts which charges C15 down toward -15 volts at a rate determined by the attack slider. When a key is released, the -15 volts is allowed to discharge through R37, 38, 39.

When a key is depressed, Q3 momentarily turns on to partially discharge C15 to 0 volts if any voltage remains from previous key depressions.

3.3.3 AR SQUELCH

(Refer to String Control Board Schematic.)

Z4B monitors the audio signal from Z3A in the String Voice Selection circuit. C10 integrates the output of Z4B and supplies it to Z4C. The output of Z4C is low (-15V) as long as an audio signal is present which reverse biases CR11 and prevents the AR from discharging faster than the decay of the audio signal.

3.3.4 ADSR BLANKING

The ADSR blanking provides a pulse to the ADSR circuit on the Synthesizer Control board which prevents the ADSR from triggering when the foot pedal is released.

3.4 Synthesizer Control Board

GENERAL: The Synthesizer Control Board contains the Synthesizer Voice Selection, Low Frequency Oscillator, Synthesizer Voltage Controlled Amplifier, String Voltage Controlled Amplifier, final Output Mix and Bass AR Envelope Generator.

3.4.1 LOW FREQUENCY OSCILLATOR

(Refer to Synthesizer Control Board Schematic.)

The LFO produces a triangle and a square wave output in a frequency range from about .1Hz to 20Hz. Z4B and C11 are an integrator which charges from current passing through R45. Z4A is a hysteretic switch whose output switches from -15

volts to +15 volts when the output of Z4B reaches -5 volts. This then reverses the direction of current through R45 and the rate control (R44) and thus the direction of integration at the output of Z4B. When the output of Z4B reaches -5 volts, the output of Z4A switches back to -15 volts and the cycle repeats.

3.4.2 SYNTHESIZER VOLTAGE CONTROLLED AMPLIFIER

(Refer to Synthesizer Control Board Schematic)

The Synthesizer Voltage Controlled Amplifier attenuates signals from the output of the VCF. The gain of the VCA is determined by the amount of current supplied to the differential pair Z2A, B. The ADSR output is connected to the control input (pin 3, Z2) via P12 pin 10. The control rejection trimmer (R14) minimizes the effect of control voltage changes on the output of the VCA by balancing the current through Z2A and Z2B. CR7, CR8 and R17 provide output protection to prevent external voltages from entering the OMNI circuits through the output jack.

3.4.3 STRING VOLTAGE CONTROLLED AMPLIFIER

(Refer to Synthesizer Control Board Schematic.)

The String Voltage Controlled Amplifier is the same circuit as the Synthesizer VCA except that it is controlled by the String AR Envelope Generator instead of the ADSR.

3.4.4 OUTPUT MIX

(Refer to Synthesizer Control Board Schematic.)

The output of the Synthesizer VCA and String VCA are mixed by Z5A. R23, the Mix slider, controls the volume of the two signals.

3.4.5 SYNTHESIZER VOICE SELECTION

(Refer to Synthesizer Control Board Schematic.)

The four pitch range push buttons, 4', 8' Synthesizer Polyphonic and 8', 16' Synthesizer Bass route the audio through Z1 to the VCF input on the Synthesizer Control Board. CR5 and CR6 disable the audio output of the first 20 notes of the polyphonic tone gates (TDA470s) when the 8' and 16' pitch ranges are selected.

3.5 Synthesizer Board

GENERAL: The Synthesizer Board contains the Voltage Controlled Filter, ADSR Envelope Generator, ADSR Gating and the Gate and Trigger Output Processing circuits.

3.5.1 VOLTAGE CONTROLLED FILTER

(Refer to Synthesizer Board Schematic.)

The four pitch ranges, 4' and 8' Polyphonic and 8' and 16' Bass, are summed and voiced on the audio input of the VCF (pin 1, M1). M1 is a 4075 Low Pass Voltage Controlled Filter. It has a cutoff of 24 dB/Octave and has a manually variable Q (resonance). The filter accepts negative control voltages (-1 volts/octave) on pin 4 to control the filter cutoff point. Z1B sums and inverts external voltages which control the VCF. R22, the CVR (Control Voltage Reset) trimmer, prevents control voltages from affecting the audio output (pin 10). The output of the VCF is routed to the Synthesizer VCA via J12, pin 5.

3.5.2 ADSR GATING

(Refer to Synthesizer Board Schematic.)

To "start" the ADSR Envelope Generator, the output of Z3A must change from 0 volts to -15 volts (Logic 1 to Logic 0). Two signals must be sent to the ADSR Gating to set up this condition: the Gate and Pulse Drive. The Gate (J12-7) is -15 volts (Logic 0) with no keys depressed, and 0 volts with one or more keys depressed. The Gate is supplied to the Reset input (Z4D pin 13) of R-S flip flop made up of Z4C and Z4D. The first negative transition on Z4C pin 8 will cause Z4C pin 10 to change from -15 volts (logic 0) to 0 volts (logic 1). Pin 10 will remain at 0 volts for as long as the Gate on J12-7 is at 0 volts.

The Pulse Drive is normally logic 0 (about -13 volts) and pulses to logic 1 (about -1 volt) every time a key is depressed. The ADSR blanking is normally logic 1, but drops to logic 0 when the sustain footswitch is released to prevent the ADSR from triggering.

The output of Z4A is, therefore, normally logic 1 (0 volts) but drops to logic 0 (-15 volts) during the Pulse Drive pulse or the ADSR blanking pulse.

Z3A will change from logic 1 to logic 0 then when Z4C has changed to logic 1 and after Z4A changes to logic 1 as well. Thus Z4A delays the ADSR "starting" until after the Pulse Drive pulse has occurred. A

second Pulse Drive will momentarily force Z3A's output to logic 0 to restart the ADSR.

3.5.3 ADSR

The ADSR Envelope Generator circuit provides a negative going DC voltage to control the VCF cutoff and the VCA.

ATTACK: When the output of Z3A changes from high to low, -15 volts is applied through CR2 and R46 to the noninverting input of follower Z2. During the attack mode, Q4 is off and R45 is disconnected from ground. Z2 directly follows the voltage on pin 3 and applies -15 volts through CR6, R52 to charge integrating capacitor C13 down.

DECAY AND SUSTAIN: Z1A is a buffer amplifier following the voltage on capacitor C13. The output of ADSR voltage approaches -10 volts, Q2 begins to turn off and R35 lowers the voltage on pin 13 of Z3D. Z3C and Z3D is a bistable latch. When pin 13 falls below the threshold of the nand gate (about -7.5 volts) the output of Z3C changes from high to low applying -15 volts from pin 10 of Z3 through CR4, R38 and CR3 thus holding Q2 off. Q4 now turns on and the voltage divider consisting of R45 and R46 establishes the Sustain Level. CR6 is now reverse biased and capacitor C13 discharges through R51 and CR5 to the level at Z2 pin 3.

RELEASE: When the gate voltage is removed, Z3B goes low which turns on Q6. The remaining voltage on capacitor C13 discharges through R53, R50 and Q6 to ground. The output of Z1A is applied to the input of follower Z2 through R59 thereby preventing the sustain and decay charge paths from affecting the release time. Q5 and Q7 permit the release slider setting on the front panel to be overridden when the sustain footswitch is depressed. Pulse Drive input is disabled by ADSR Release Control pulse which occurs whenever the footswitch is released.

3.6 Phaser Board

GENERAL: The Phaser Board contains three identical parallel Phase Shifters each modulated by Low Frequency Oscillators. The Phasers are chiefly responsible for the orchestral string effects of the OMNI.

3.6.1 LFO

(See Section 3.4.1 for details of the Low Frequency Oscillator circuit.)

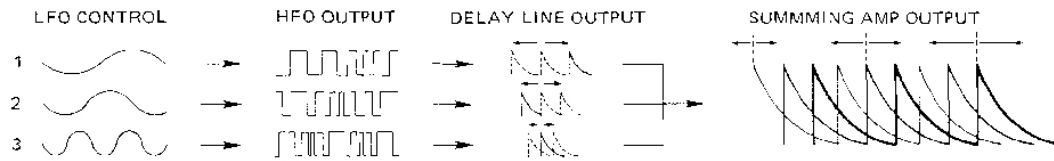

The three Low Frequency Oscillators are used to modulate the Phase Shifters varying the delay time up to .8msec.

Pin 1 of Z105A is a triangle waveform which is clipped to approximate a sinewave. Z106B connects R128 in parallel with R127 when the chorus switch is depressed, which slows down the LFO.

3.6.2 HIGH FREQUENCY OSCILLATOR

(Refer to Phaser Board Schematic)

Voltage controlled High Frequency Oscillators are used to control delay time of each phase shifter.

Z104B is a COSMOS one shot which uses the inherent capacitance of COSMOS gates (typically 5 pf) as the timing capacitor on T2. The "capacitor" is charged by Q101. Once the "capacitor" is charged to maximum, the Q output (pin 10) changes to logic 0 which resets the one shot.

Z104A is used to maintain oscillation in Z104B: should Z104B cease oscillation, or not begin to oscillate after power up, the Q output of Z104 discharges Z104B pin 14 to start Z104B oscillating. The Q output of Z104A is a logic 1 as long as Z104B oscillates.

Q102 and Q101 are a linear voltage to exponential current converter which determines the frequency of the H.F.O. R116 (calibrate) sets the initial frequency of the H.F.O. The sinewave from the LFO controls Q101, 102 to vary the H.F.O. exponentially. R119 is placed in parallel with R118 to increase the depth of modulation when the chorus switch is selected by varying the depth of frequency change produced by Q102-Q101.

3.6.3 DELAY CIRCUITS

(Refer to Phaser Board Schematic.)

Z102 is an analog delay line whose delay time is controlled by the frequency of the square wave on pins 2 and 12 (typically 50KHz.). Pin 2 and 12 must be square waves of the same exact frequency, 180 out of phase. The audio input of the device is pin 3,

the outputs are Pin 13 and 14.

Z103 is a latching flip flop which converts the high frequency pulses from Z104B to square waves (Q and Q).

3.6.4 FINAL MIX

(Refer to Phaser Board Schematic.)

The outputs of the three Phase Shifters are summed by Z1 and supplied to the string VCA on the Synthesizer Board.

3.7 Power Supply

3.7.1 +15 VOLT SUPPLY

Z1 contains a voltage reference which supplies approximately +7 volts to pin 6 of Z1. This voltage is connected through pin 5 to the noninverting input of an op amp. The output of the op amp is connected to an emitter follower, also located in Z1, which controls the pass transistor (Q1). Should the output of the power supply change, the voltage at the junction of R11 and R12 will supply the inverting input of the op amp in Z1 with the voltage difference. The op amp will then supply a correction voltage to the emitter follower and pass transistor (Q1) and bring the power supply's voltage to normal.

3.7.2 -15 VOLT SUPPLY

The -15 volt supply derives its regulation from the +15 volt supply through R14. When the output of the -15 volt supply is at the correct voltage, the junction of R14 and R15 is 0 volts. Z2 is referenced to 0 volts through R2. Should the output of the minus supply increase, the voltage on pin 2 of Z2 also increase. Z2 then forces Q2 to supply more current, thereby lowering the output to -15 volts.

3.7.3 SHORT CIRCUIT PROTECTION

R7 and the transistor in Z1 connected to pins 2 and 3 limit the +15 supply's current to a maximum of 800 milliamps. Q3 and R5 limit the -15 supply's current to a maximum of 1000 milliamps.

SECTION 4 ASSEMBLY/DISASSEMBLY

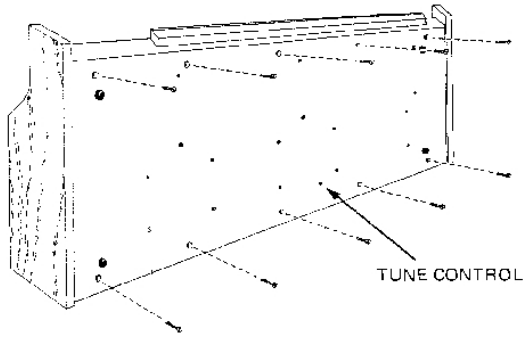

A. Remove all 10 screws as indicated.

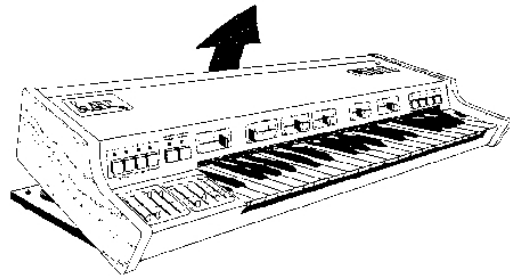

B. Lift rear of instrument 3-4 inches (high enough to clear Tune Control).

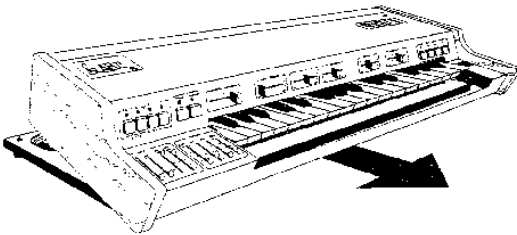

C. Pull forward 2-3 inches.

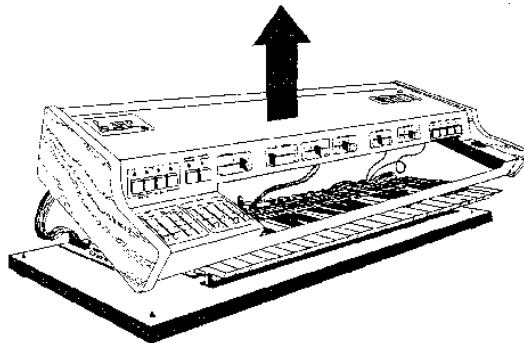

D. Lift chassis straight up.

SECTION 5 GENERAL INFORMATION





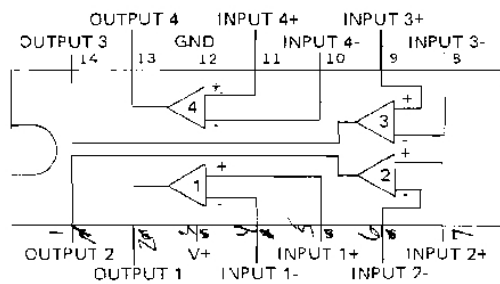

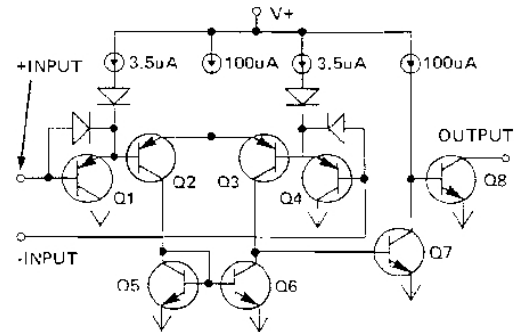

5.1 LM339 Comparator

The LM339 contains four independent precision voltage comparators. With an open collector output, the LM339 is compatible with TTL and CMOS.



In the OMNI, pin 12 of LM339s are connected to -15V. Thus the output states of the device are open (voltage determined by external circuitry) or -15V.



SECTION 6		CALIBRATIONS
6.1 Synthesizer Board Trim Procedure		
REF.	TRIMMER	TRIM PROCEDURE
R22 	VCF CVR	<ol style="list-style-type: none"> 1. Monitor pin 10 of filter module M1 with an oscilloscope. 2. Put the VCF FREQ slider and VCF RESONANCE slider fully DOWN. 3. Put the VCF "ADSR" slider fully UP. 4. Set the ADSR sliders as follows: ATTACK DOWN, DECAY 3/4 UP, SUSTAIN DOWN, RELEASE DOWN. 5. Adjust R22 for minimum amplitude when keys are depressed.
R16 	VCF CAL	<ol style="list-style-type: none"> 1. Monitor pin 10 of filter module M1 with an oscilloscope. 2. Clip a 33K ohm resistor from pin 10 of M1 to pin 2. 3. Put the VCF FREQ slider fully DOWN and the VCF RESONANCE slider fully UP; put all other sliders DOWN. 4. Adjust R16 for a 16Hz sine wave.
6.2 Synthesizer Control Board Trim Procedure		
R14 	SYNTH VCA CVR	<ol style="list-style-type: none"> 1. Monitor the high level output of the Omni with an oscilloscope. 2. Set all VOICE SELECTION switches OFF (out). 3. Put the MIX slider fully LEFT (synthesizer). 4. Put the MASTER VOLUME fully RIGHT (maximum). 5. Set ADSR sliders as follows: ATTACK DOWN, DECAY 3/4 UP, SUSTAIN DOWN, RELEASE DOWN. 6. Put all other sliders at minimum. 7. Adjust R14 for minimum deflection of the oscilloscope trace while repeatedly depressing keys.
R33 	STRING VCA CVR	<ol style="list-style-type: none"> 1. Perform the synth. VCA CVR trim procedure. 2. Move the MIX slider to fully RIGHT (string). 3. Depress (turn on) the STRING BASS voice selection switch (only). 4. Adjust R33 for minimum deflection of the oscilloscope trace while repeatedly depressing keys in the highest octave.
6.3 Phaser Board Trim Procedure		
R116 	HFO CAL 1	<ol style="list-style-type: none"> 1. Monitor TP7 (Z102) with a frequency counter. 2. Attach a 100K ohm resistor from +15V supply to TP6. 3. Adjust R116 for an 11 microsecond period square wave (+0.1 microseconds).
R216 	HFO CAL 2	<ol style="list-style-type: none"> 1. Monitor TP9 with a frequency counter. 2. Attach a 100K ohm resistor from the +15V supply to TP8. 3. Adjust R216 for a 20.4 microsecond period square wave (+0.1 microseconds).
R316 	HFO CAL 3	<ol style="list-style-type: none"> 1. Monitor TP11 with a frequency counter. 2. Attach a 100K ohm resistor from the +15V supply to TP10. 3. Adjust R316 for a 11.3 microsecond period square wave (+0.1 microseconds).
6.4 Power supply Trim Procedure		
R19 	+15 VOLT SET	<ol style="list-style-type: none"> 1. Monitor the power supply's +15 volt output with a digital voltmeter. 2. Adjust R19 for exactly +15.00 volts.
R20 	-15 VOLT SET	<ol style="list-style-type: none"> 1. Set R5 (+15 volts) first. 2. Put the digital voltmeter's ground lead on the power supply's -15 volt output and put the meter's plus lead on the power supply's ground output. 3. Adjust R20 for exactly +15.00 volts (reversed polarity).

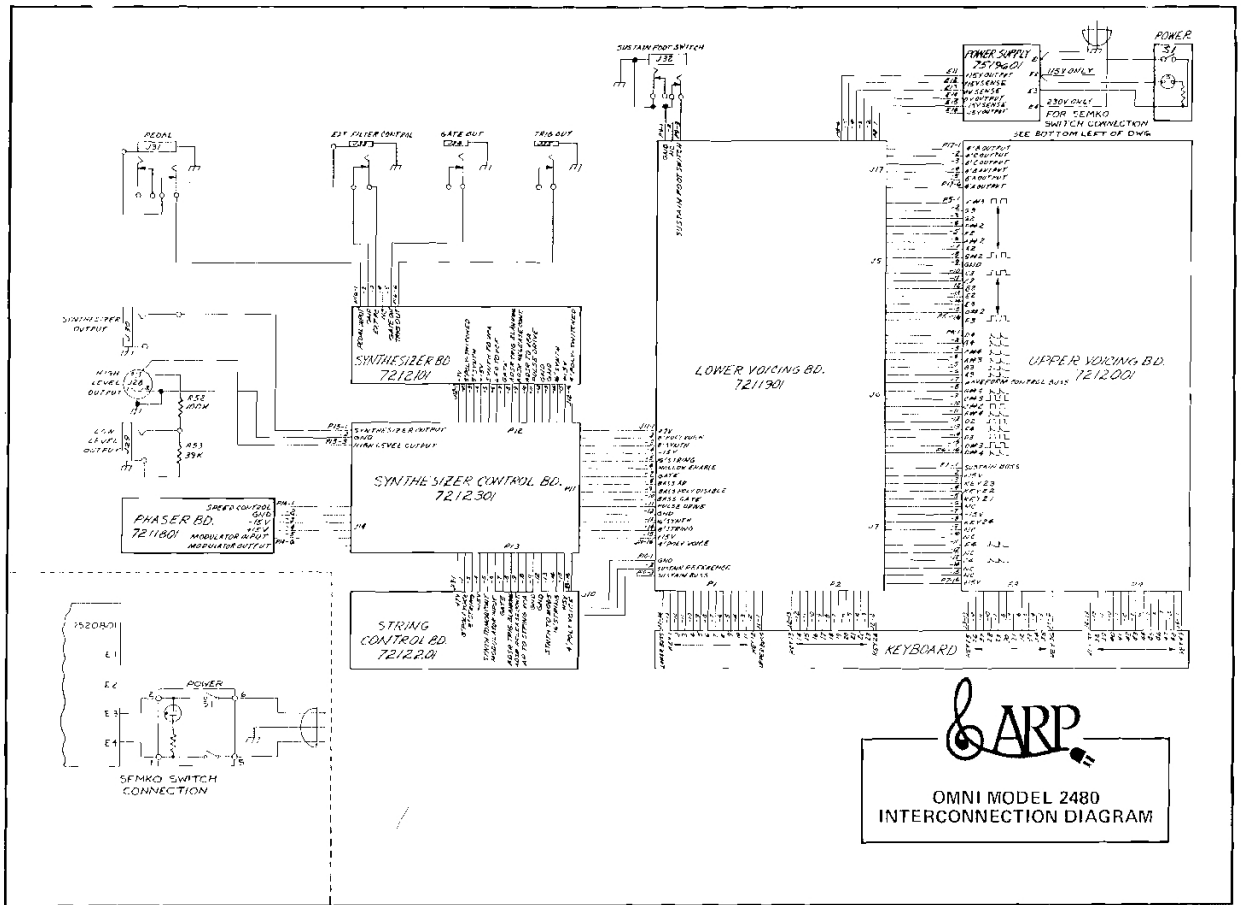

ARP
 OMNI MODEL 2480
 INTERCONNECTION DIAGRAM

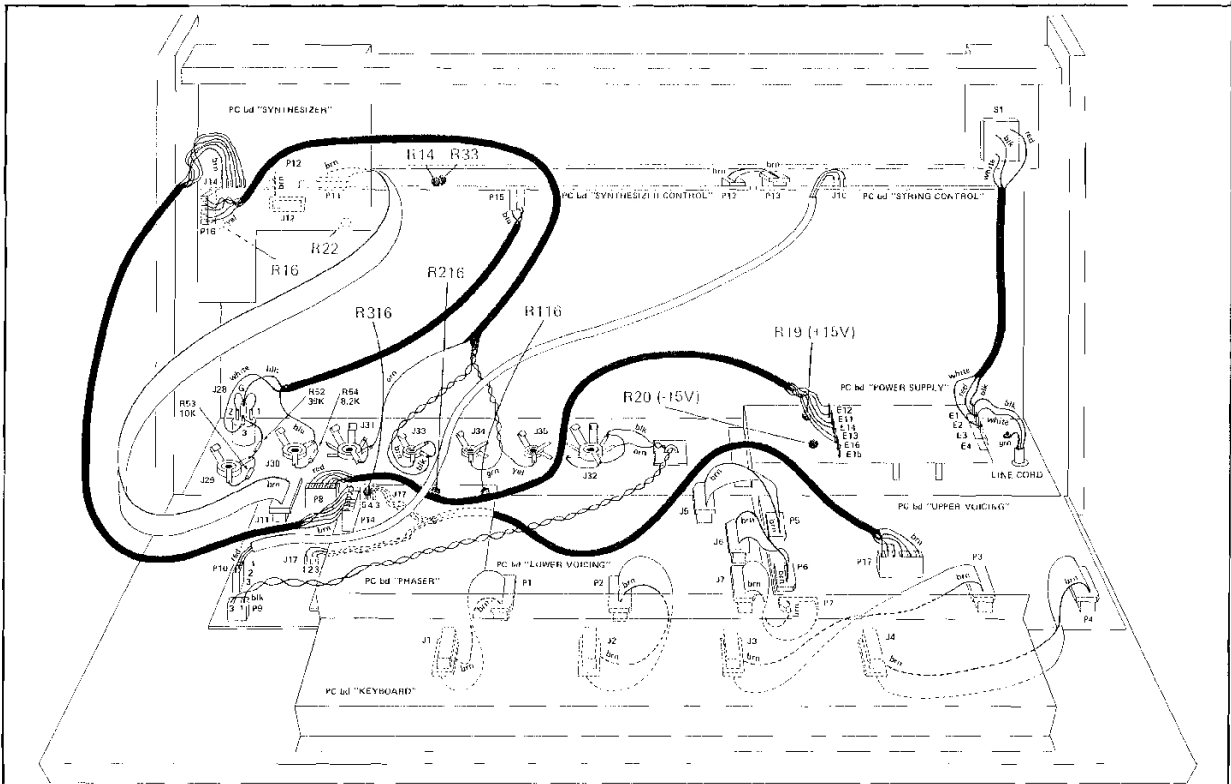

DESCRIPTION	LINE CORD CONNECTIONS			POWER CORD CONNECTIONS		
				PIN 2	PIN 1	NONE
FINAL ASSY 240V SEMKO	BRN TO POWER SWITCH, PIN 5	BLU TO POWER SWITCH, PIN 6	GRN/YEL TO GND SCREW	TO POWER SUP E-3	TO POWER SUP E-4	
FINAL ASSY 170V CSA, LA	BLK TO POWER SUPPLY, E-1	WHT TO POWER SUPPLY, E-2	GRN TO GND SCREW	BLK TO POWER SUPPLY, E-1	RED TO POWER SUPPLY, E-2	WHT TO POWER SUPPLY, E-3
FINAL ASSY 240V STANDARD	BRN TO POWER SUPPLY, E-1	BLU TO POWER SUPPLY, E-4	GRN/YEL TO GND SCREW	BLK TO POWER SUPPLY, E-1	RED TO POWER SUPPLY, E-2	WHT TO POWER SUPPLY, E-3

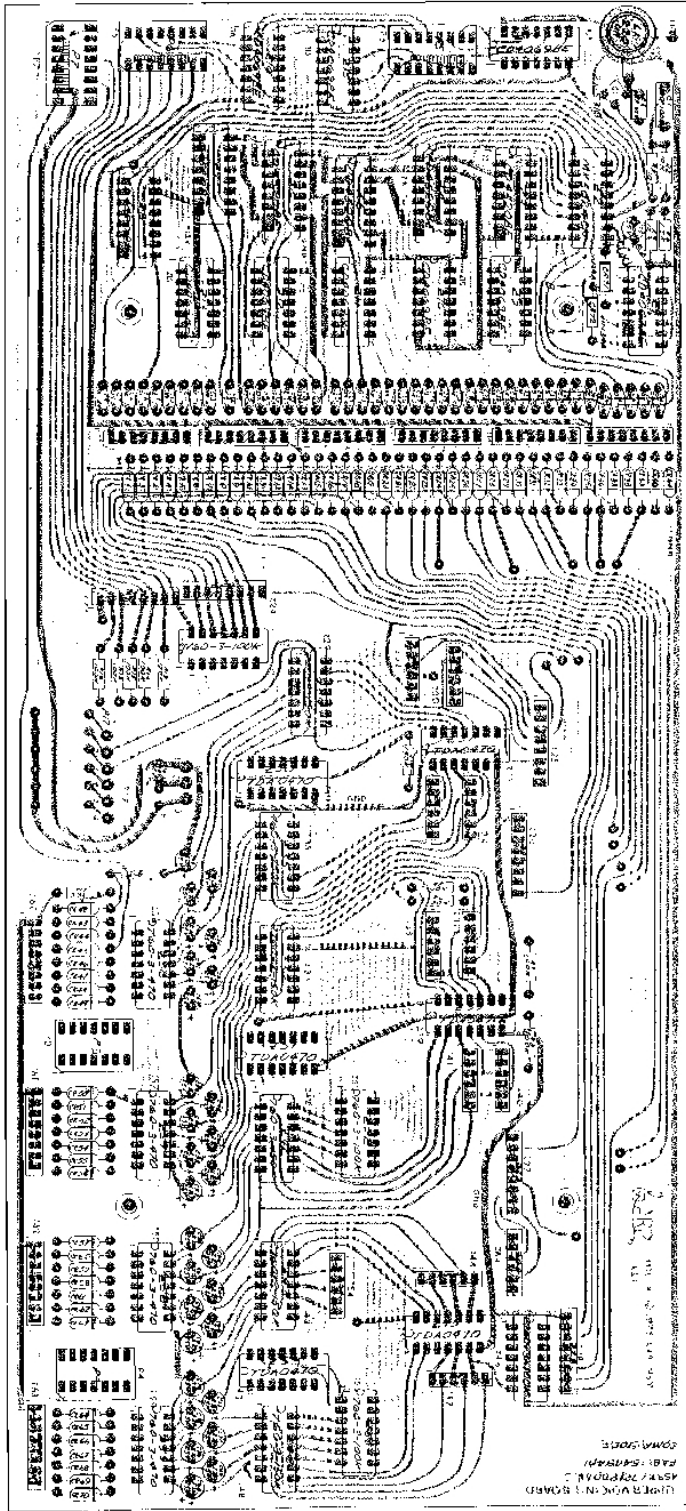

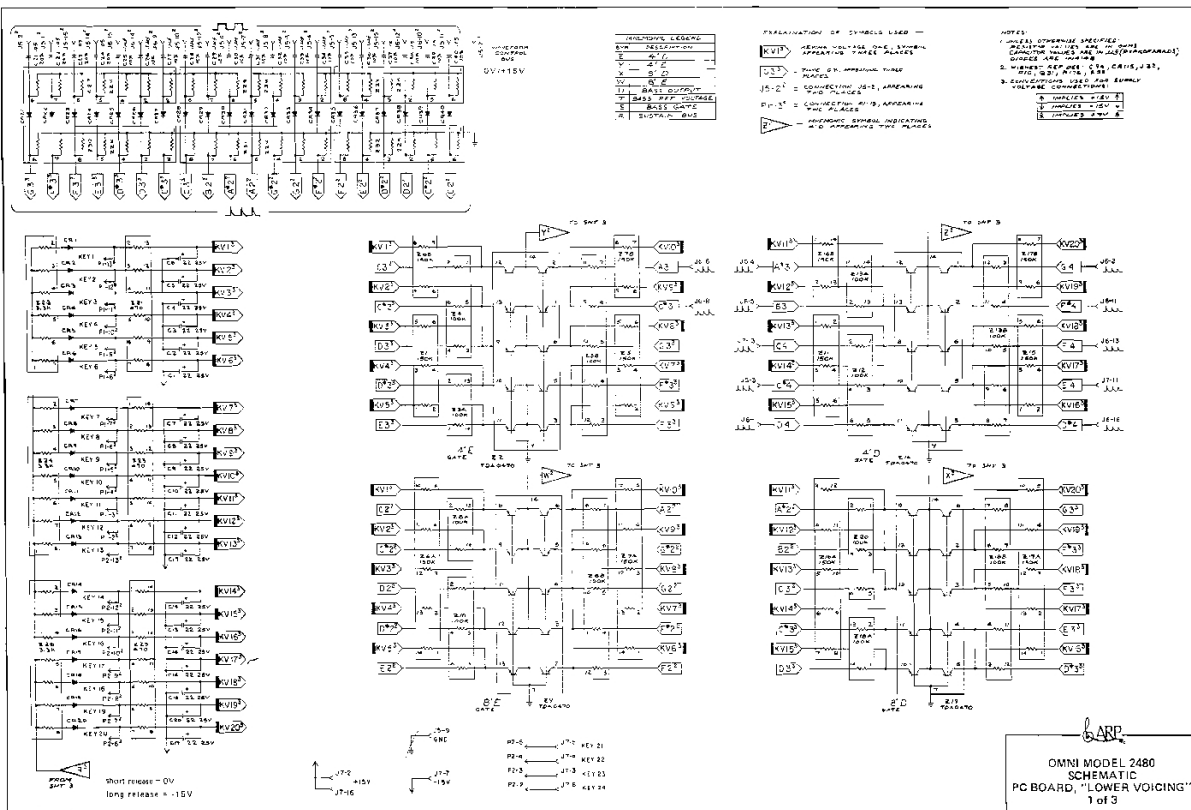

 OMNI MODEL 2480
 ASSEMBLY
 PC BOARD, "UPPER VOICING"

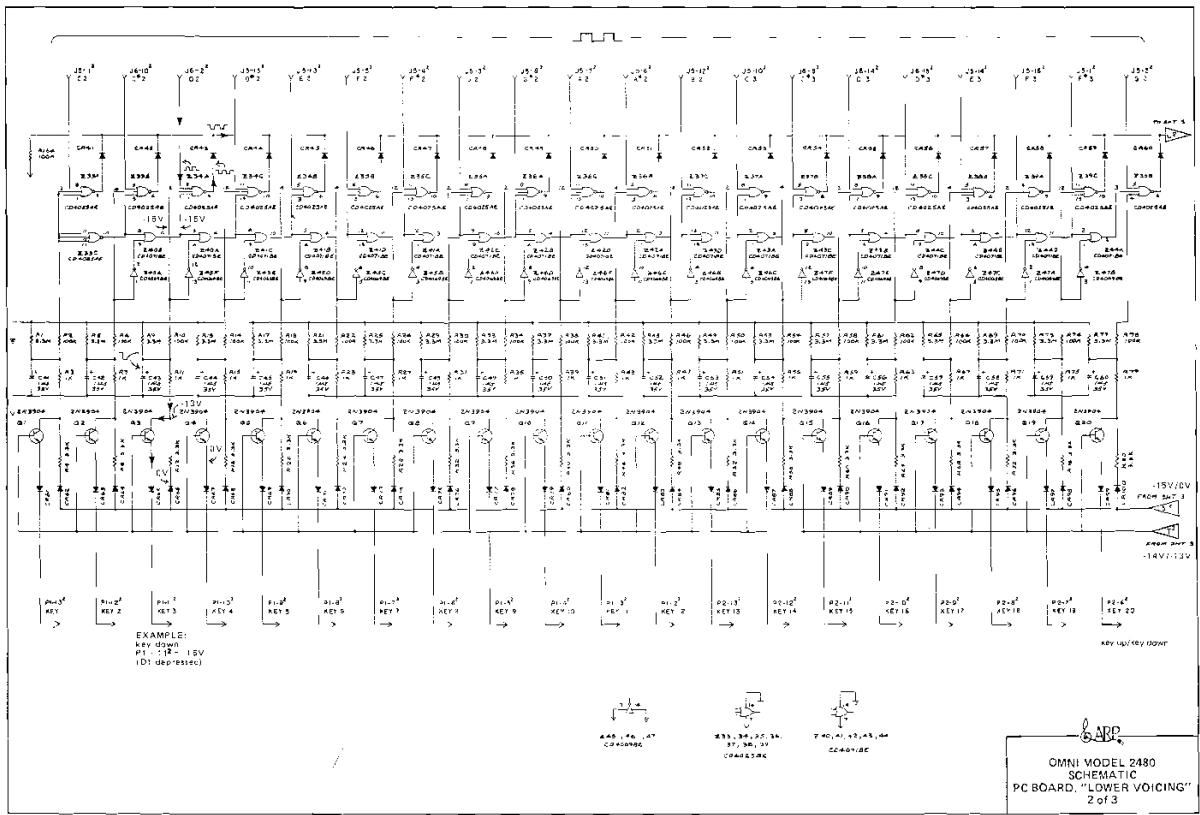

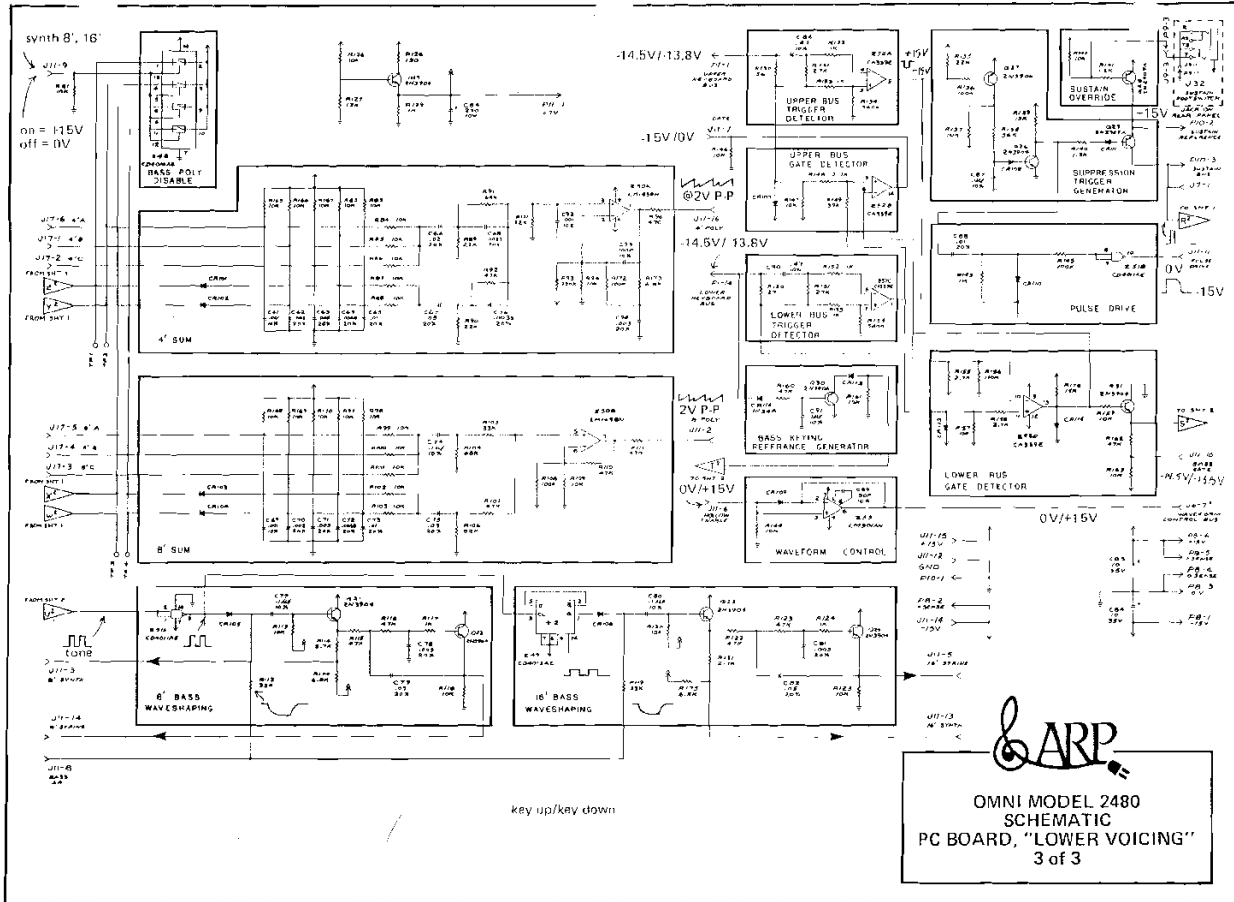





 OMNI MODEL 2480

 SCHEMATIC

 PC BOARD, "LOWER VOICING"

 3 of 3

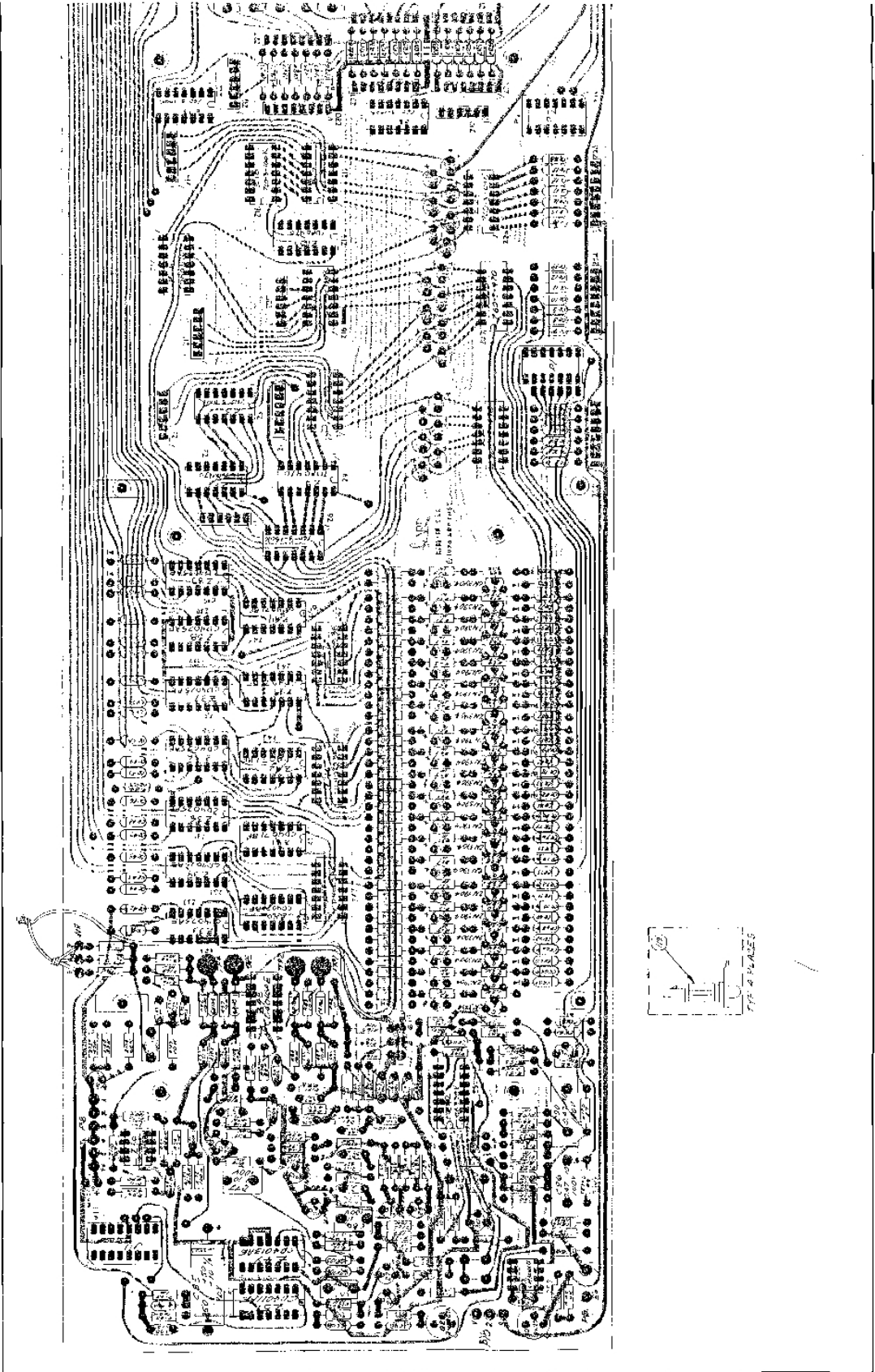

TYPE 4 PLAZES

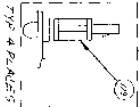
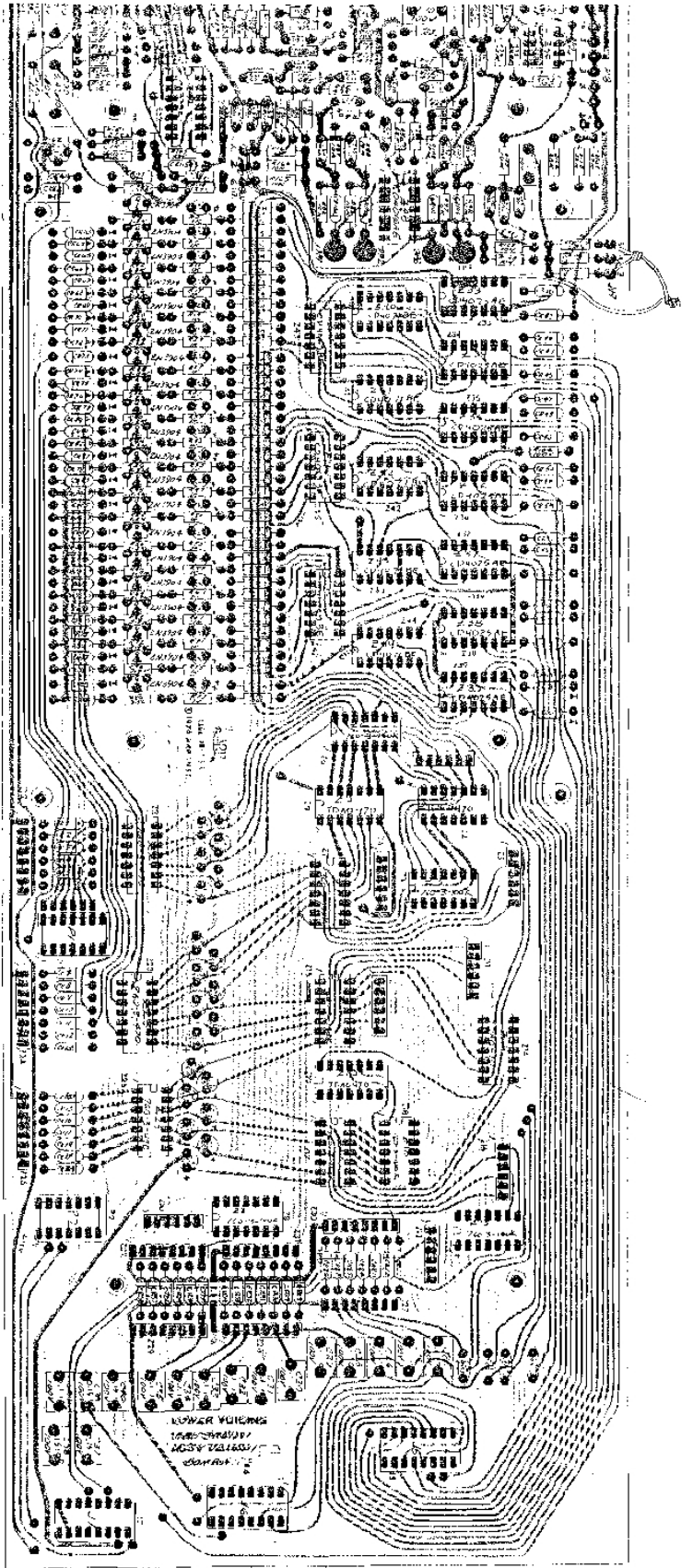

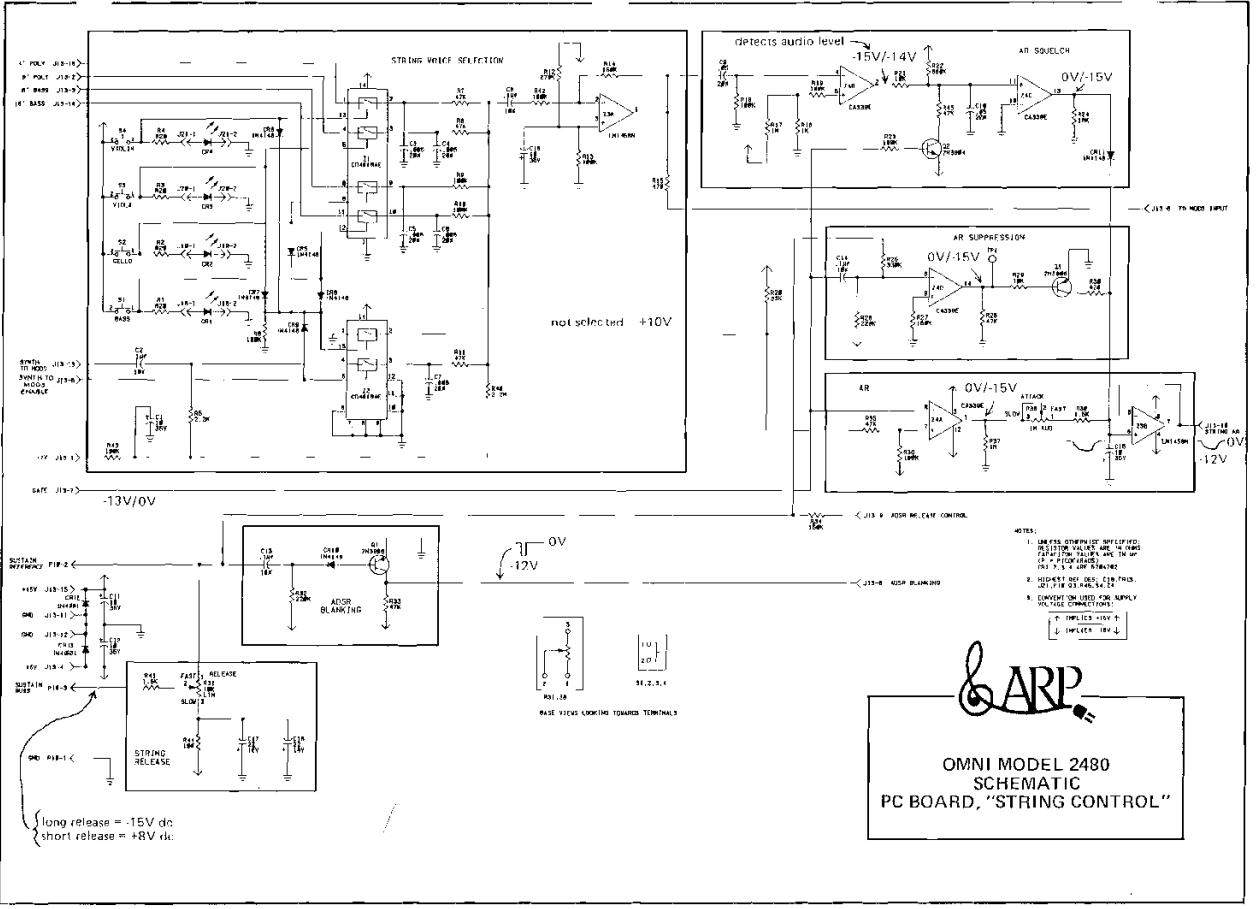

 OMNI MODEL 2430
 ASSEMBLY
 PC BOARD "LOWER VOICING"

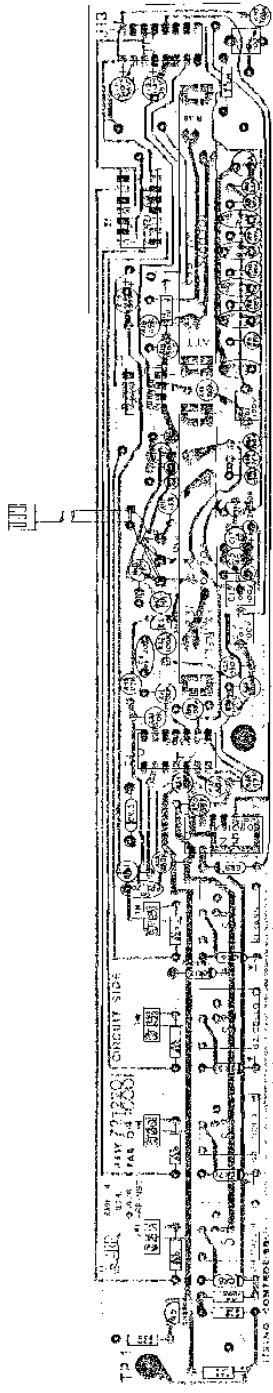

OMNI MODEL 2480
SCHEMATIC
PC BOARD, "STRING CONTROL"

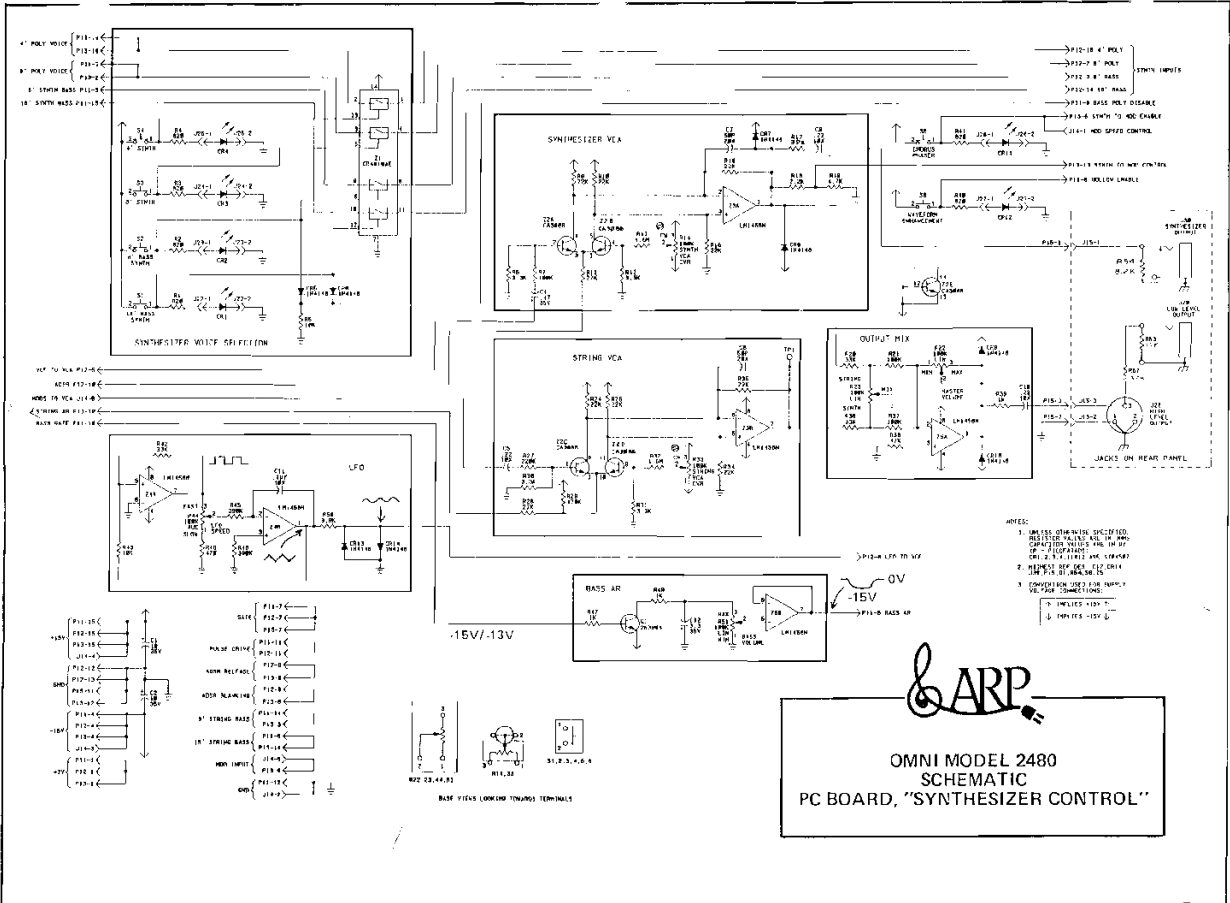

OMNI MODEL 2480
ASSEMBLY
PC BOARD "STRING CONTROL"



OMNI MODEL 2480
SCHEMATIC
PC BOARD, "SYNTHESIZER CONTROL"

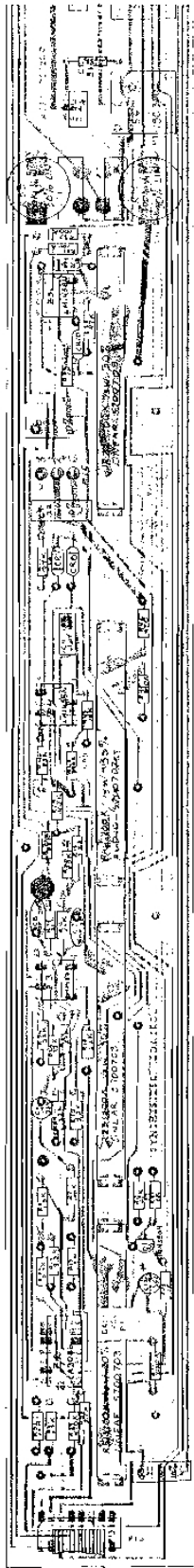

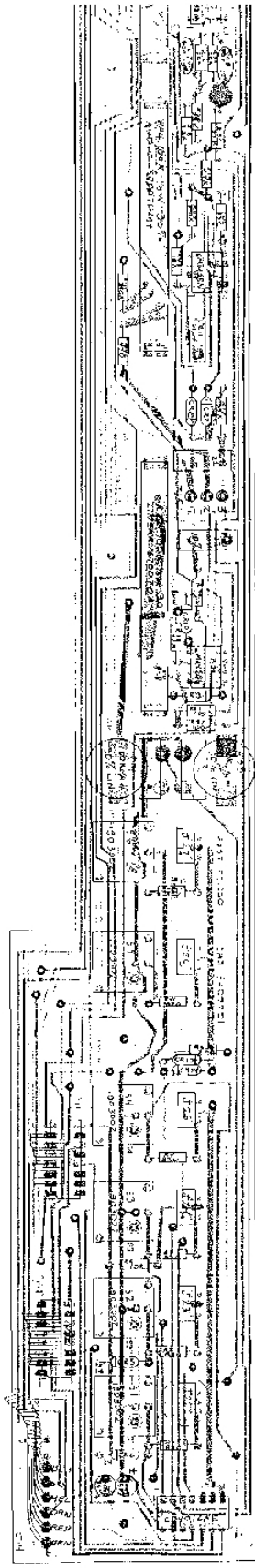



 OMNI MODEL 2480

 ASSEMBLY

 PC BOARD, "SYNTHESIZER CONTROL"



OMNI MODEL 2480
ASSEMBLY
PC BOARD, "SYNTHESIZER"
(REVISED)

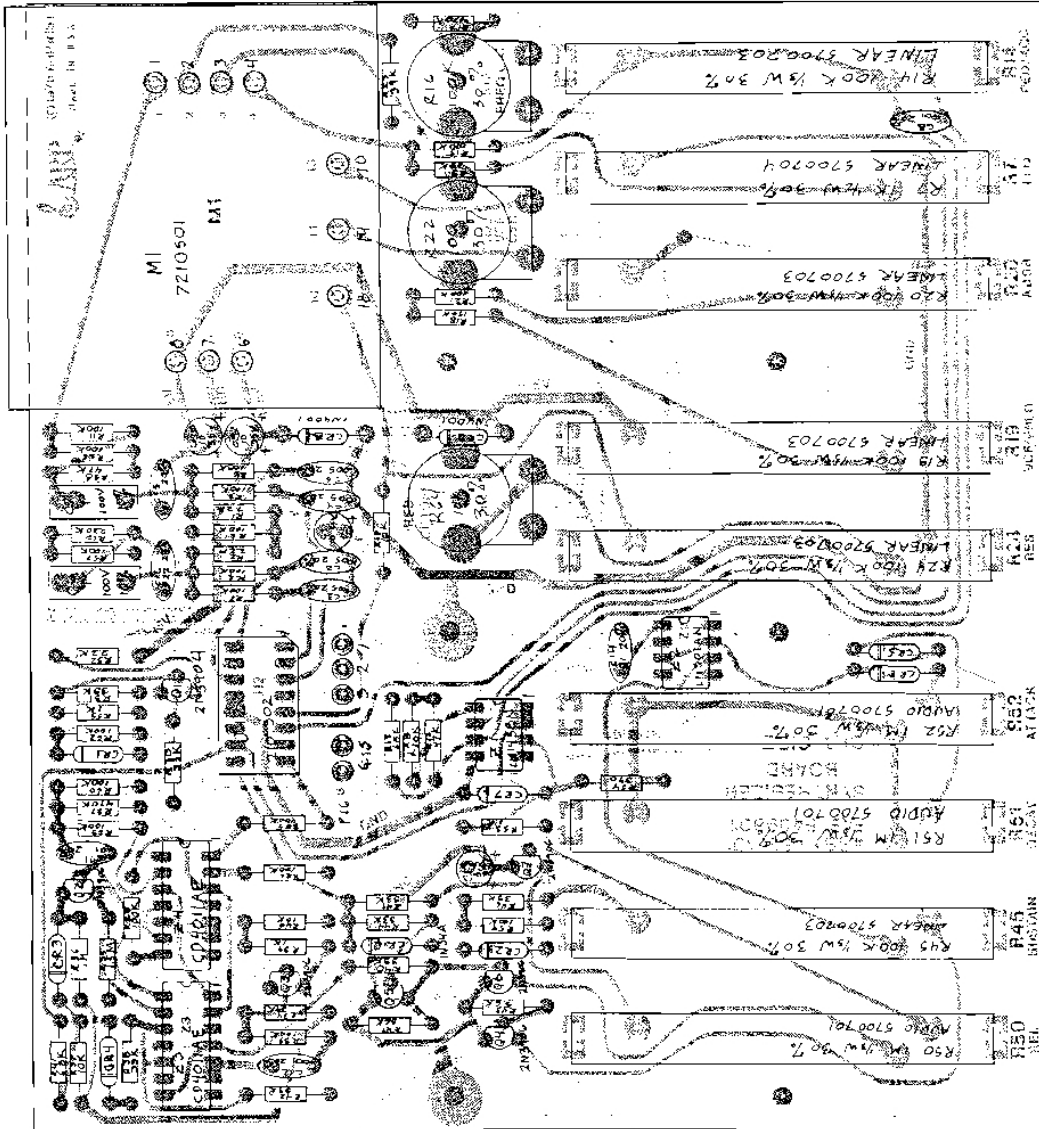

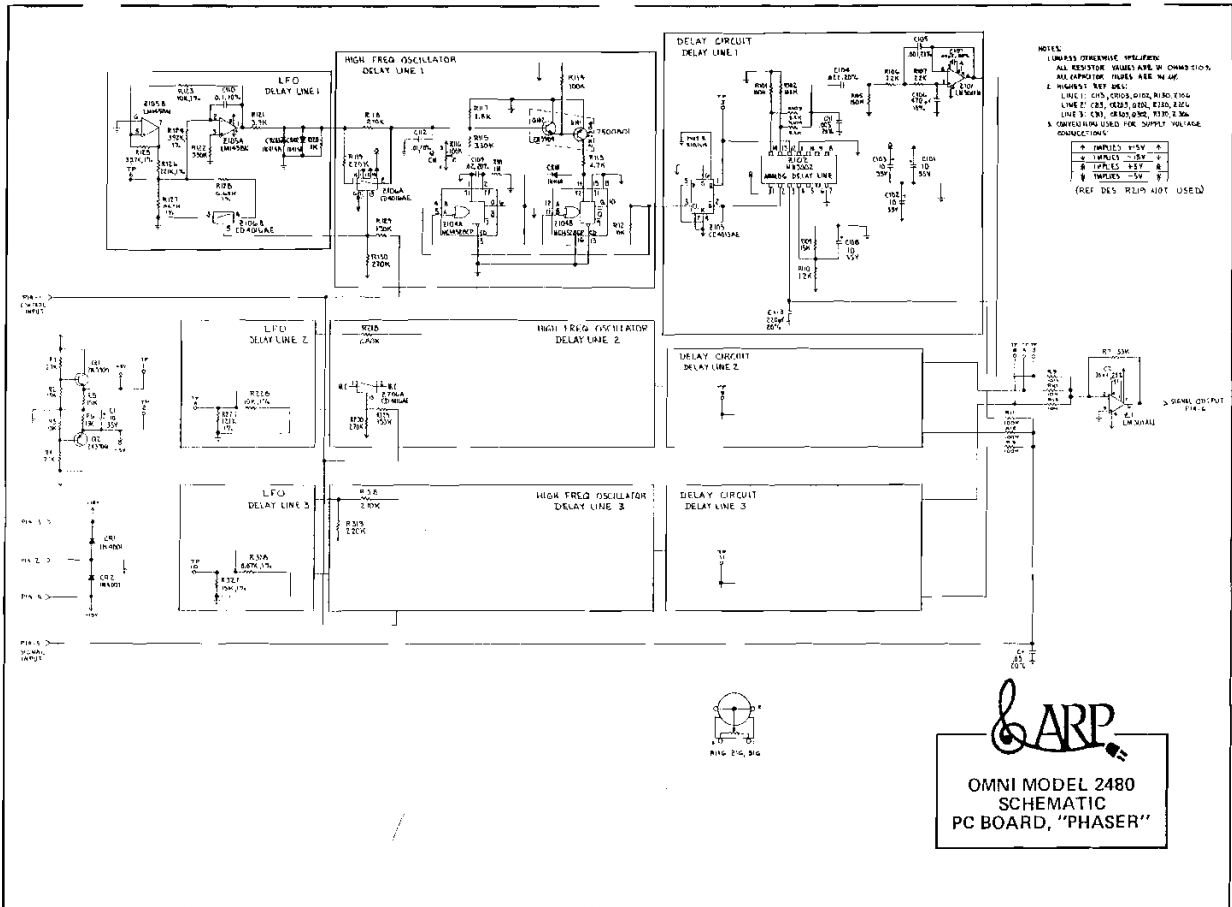



OMNI MODEL 2480
ASSEMBLY
PC BOARD, "PHASER"

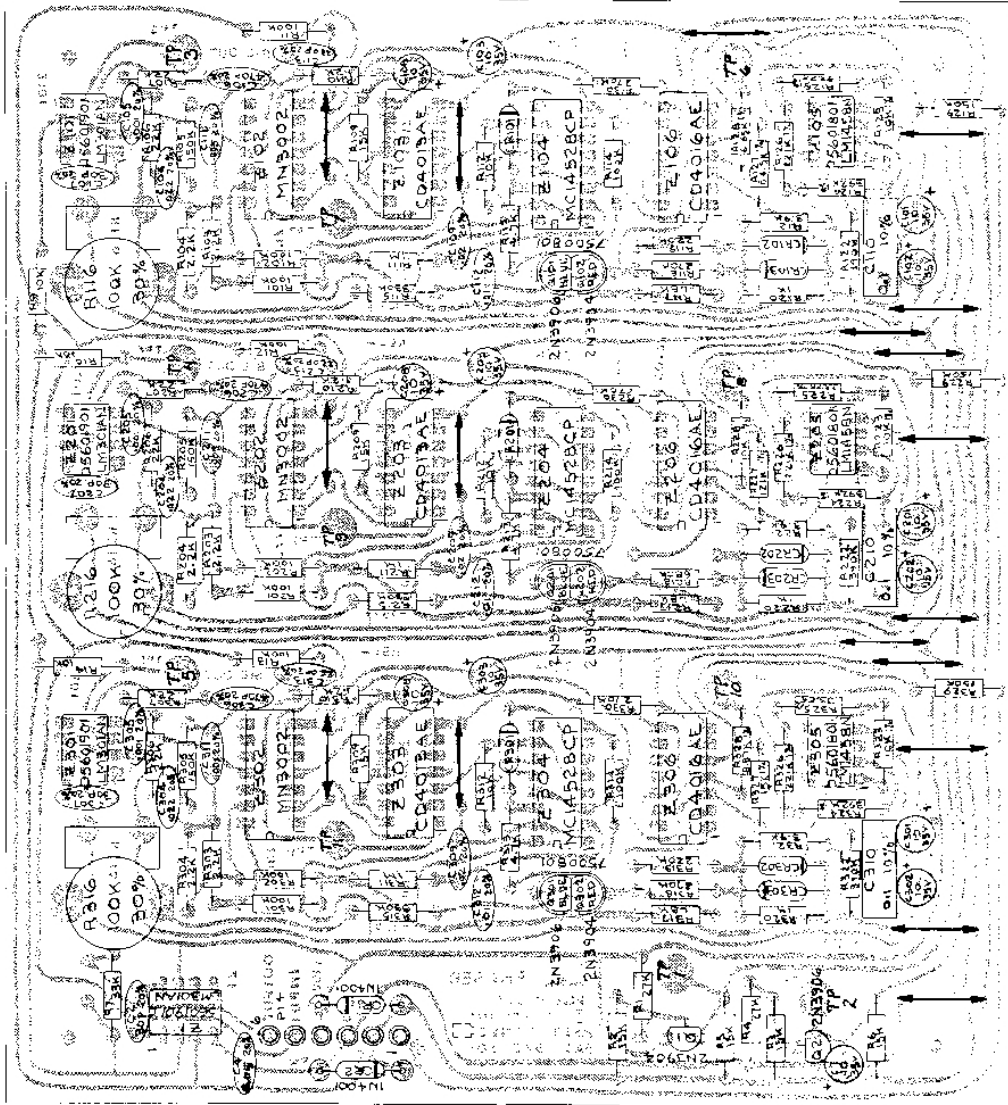

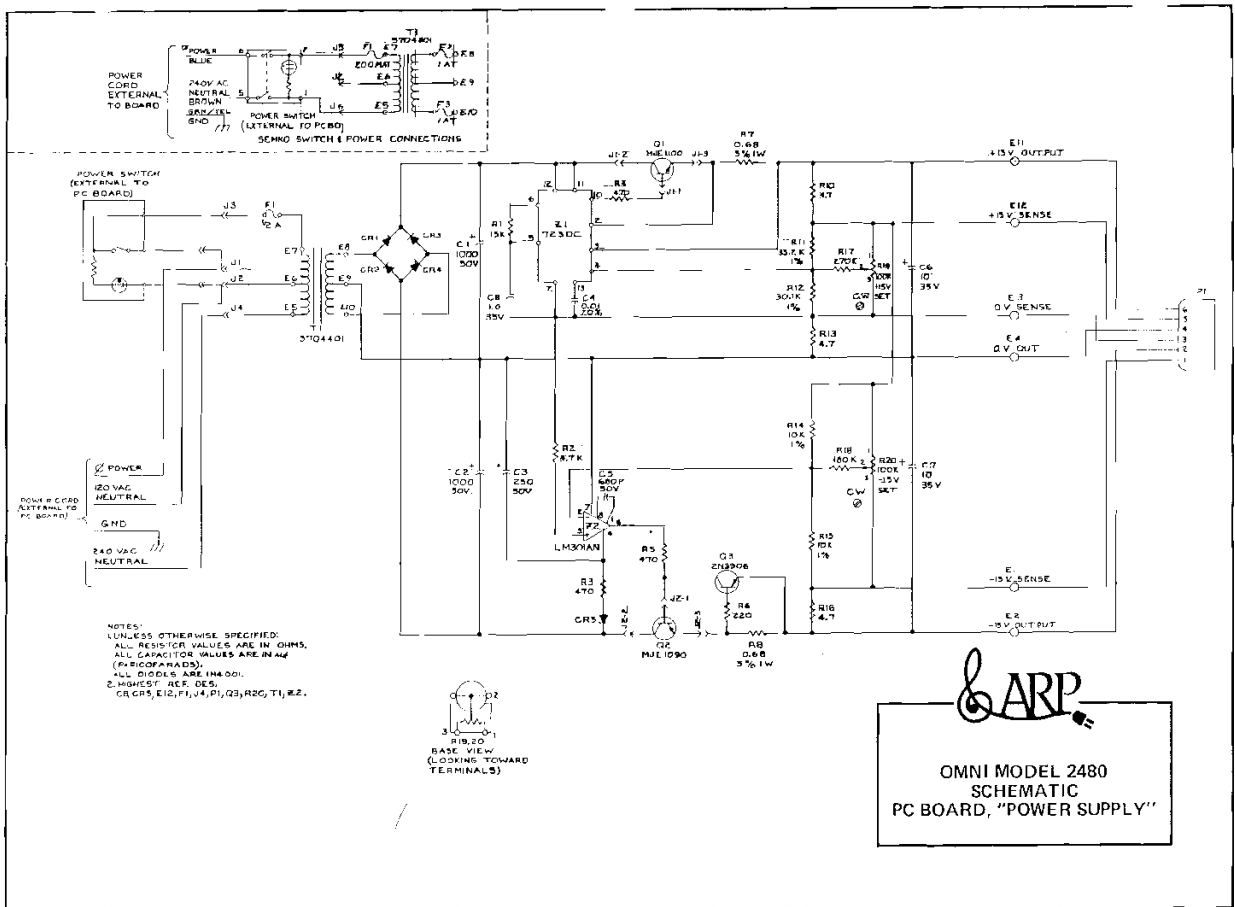

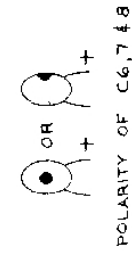
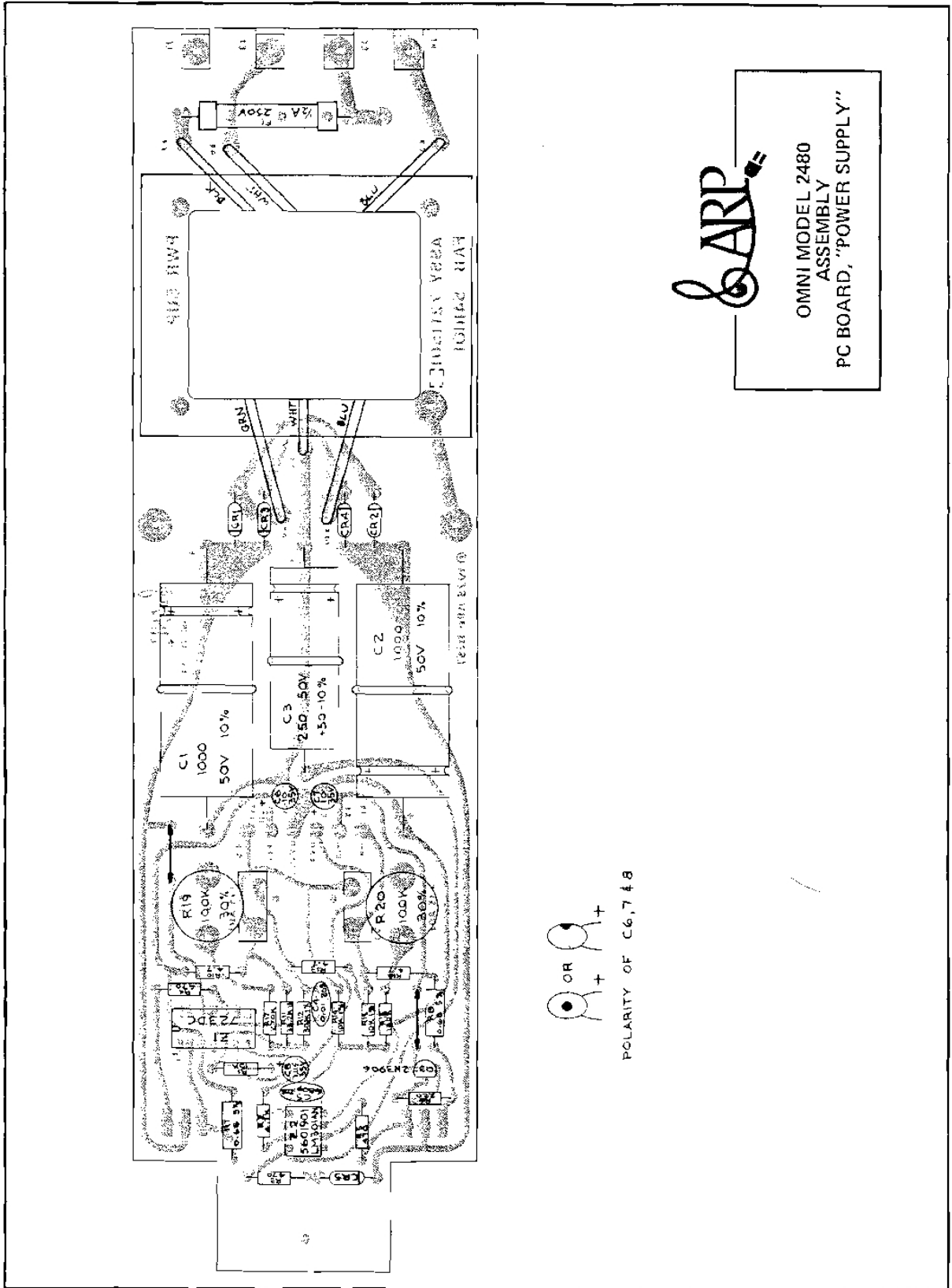

OMNI MODEL 2480
ASSEMBLY
PC BOARD, "POWER SUPPLY"



OMNI MODEL 2480
ASSEMBLY
PC BOARD, "SYNTHESIZER"
(ORIGINAL)

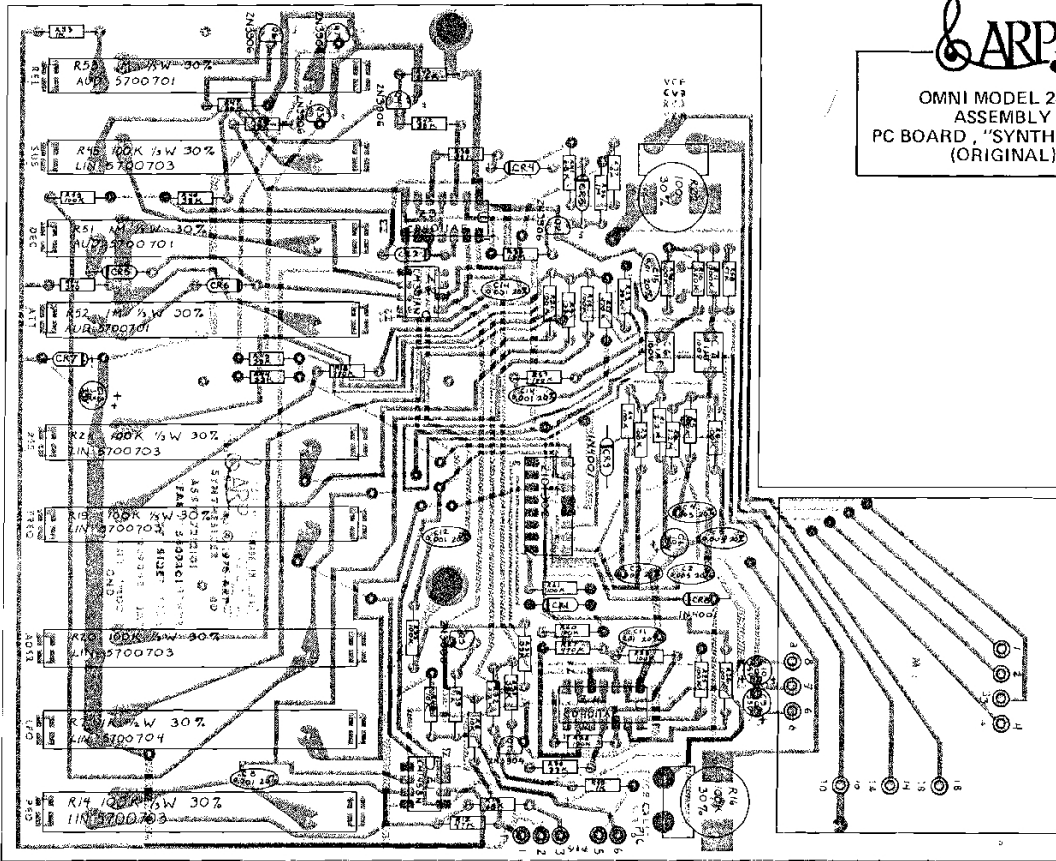

SECTION 9

PARTS LIST

PC BOARD, "LOWER VOICING"

REFERENCE	ARP PART NUMBER	ARP/MFG NUMBER	DESCRIPTION
CR114	1200101	1N34A	DIODE, GERMANIUM
CR1-113,115	1200301	1N4148	DIODE, SIGNAL
Z53	1400201	LM301AN	IC, OP AMPL
750	1401101	LM1458N	IC, OP AMPL, DUAL
Z52	1405401	CA339E	IC, QUAD COMPARATOR
Z2,9,14,19	1401201	1DA0470	IC, GATE, 12 X 11, ORGAN
Z51	1400601	CD4011AE	IC, GATE, 4 X 21, NAND
Z49	1404401	CD4013AE	IC, DUAL D, FF, SET/RESET
Z48	1404501	CD4016AE	IC, QUAD BILATERAL SWITCH
Z33,34,35,36,37,38,39	1404601	CD4025AE	IC, GATE, 3 X 31, NOR
Z45,46,47	1405801	CD4069BE	IC, HEX INVERTER
Z40,41,42,43,44	1405101	CD4071BE	IC, GATE, 4 X 21, OR
Q1-26,31	1302901	2N3904	TSTR, NPN, GP
Q27,30	1303001	2N3906	TSTR, PNP, GP
Q28,29	1300401	2N2907A	TSTR, PNP, GENERAL PURPOSE
Z21,23,25	1406101	760-3-470	IC, RES NETWORK, 14-PIN, 470 OHM
Z22,24,26	1406001	750-81-3.3K	IC, RES NETWORK, 8-PIN, 3.3K
Z27,28,29,30,31,32	1406002	750-81-22K	IC, RES NETWORK, 8-PIN, 22K
Z4,10,12,20	1405901	750-63-100K	IC, RES NETWORK, 6-PIN, 100K
Z3,8,13,18	1406102	760-3-100K	IC, RES NETWORK, 14-PIN, 100K
Z1,5,11,15	1405902	750-63-150K	IC, RES NETWORK, 6-PIN, 150K
Z6,7,16,17	1406103	760-3-150K	IC, RES NETWORK, 14-PIN, 150K
C41-50	1100608	G-0-001-G-10-0	CAP, TANT, 1UF, 35V, 10%
C83,84	1100612	G-0-010-G-20-0	CAP, TANT, 10UF, 35V, 20%
C1-20	1100613	G-0-022-F-20-0	CAP, TANT, 22UF, 25V, 20%
C85	1101701	TAD250TJ10	CAP, ELECT, 250JF, 10V, +50-10%
C25-36,74,77,80,87,91	1102001	120-20-0497	CAP, PLASTIC, .1UF, 100V, 10%
J5,6,7,11	21C1302	16-511-10	SOCKET, DUAL-IN-LINE, 16-PIN
P1,2	21C1301	14-511-10	SOCKET, DUAL-IN-LINE, 14-PIN

PC BOARD, "UPPER VOICING"

REFERENCE	ARP PART NUMBER	ARP/MFG NUMBER	DESCRIPTION
CR1-70	1200301	1N4148	DIODE, SIGNAL
CR71, 72	1200101	1N34A	DIODE, GERMANIUM
Q1	1302701	2N5910	TSTR, PNP, SWITCH, H5
Z1	1404201	CD4007AE	IC, CMOS PAIR PLUS INVERTER
Z2	1405701	MK50240N	IC, TOP OCTAVE DIVIDER
Z3-8	1405201	CD4520BE	IC, DUAL BINARY UP COUNTER
Z9-16	1405801	CD4069BE	IC, HEX INVERTER
Z31,39,45,50,51,53	1401201	TDA0470	IC, GATE, 12 X 11, ORGAN
Z56-59	1406101	760-3-470	IC, RES NETWORK, 14-PIN, 470 OHM
Z60-63	1406001	750-81-3.3K	IC, RES NETWORK, 8-PIN, 3.3K
Z17-28	1406002	750-81-22K	IC, RES NETWORK, 8-PIN, 22K
Z30,32,33,38,40,54,64	1405901	750-63-100K	IC, RES NETWORK, 6-PIN, 100K
Z46,49,52,55	1406102	760-3-100K	IC, RES NETWORK, 14-PIN, 100K
Z34,37,41,44,47	1405902	750-63-150K	IC, RES NETWORK, 6-PIN, 150K
Z29,35,36,42,43,48	1406103	760-3-150K	IC, RES NETWORK, 14-PIN, 150K
C4,75	1100612	G-0-010-G-20-0	CAP, TANT, 10UF, 35V, 20%

C46-74	1100613	G-0-022-F-20-0	CAP, TANT, 22UF, 25V, 20%
L1	1500401	556-3341-24	COIL, ADJ, 220UH, ±20%
	2101301	14-511-10	SOCKET, DUAL-IN-LINE, 14 PIN
P5,6,7	2200808	5142-004	CABLE, INTERCONNECT, 16 PIN, 4IN.
PC BOARD, "PHASEK"			
REFERENCE	ARP PART NUMBER	ARP/MFG NUMBER	DESCRIPTION
CR1,2	1200201	1N4001	RECT, 50V, 1A
CR101,103,201-203,301-303	1200301	1N4148	DIODE, SIGNAL
Q1	1302901	2N3904	TSTR, NPN, GP
Q2	1303001	2N3906	TSTR, PNP, GP
Q101,102,201,202,301,302	7500801		TSTR ASSY, NPN/PNP
Z105,205,305	1401101	LM1458N	IC, OP AMPL, DUAL
Z1, 101, 201, 301	1400801	LM301AN	IC, OP AMPL
Z102,202,302	1405501	MN3002	IC, CD DELAY LINE
Z103,203,303	1404401	CD4013AE	IC, DUAL 'D', FF, SET/RESET
Z106,206,306	1404501	CD4016AE	IC, QUAD BILATERAL SWITCH
Z104,204,304	1405301	MC14528CP	IC, DUAL, MONO, MULTIVIBRATOR
R116,216,316	1000915	U201R104B	POT, ROTARY TRIM, 100K, 1/2W, 30%
C1,101,102,103,108,201, 202,203,301,302,303,208,308	1100612	G-010-G-20-0	CAP, TANT, 10UF, 35V, 20%
PC BOARD, "SYNTHESIZER"			
REFERENCE	ARP PART NUMBER	ARP/MFG NUMBER	DESCRIPTION
CR5,6,7,8,9,10,13,14	1200301	1N4148	DIODE, SIGNAL
Q1	1302901	2N3904	TSTR, NPN, GP
Z2	1400501	CA3086	IC, TSTR ARRAY
Z1	1404501	CD4016AE	IC, QUAD BILATERAL SWITCH
Z3,4,5	1401101	LM1458N	IC, OP AMPL, DUAL
R44	5700702		POT, SLIDE, AUDIO, 100K, 1/3W, 30%
R22,23,51	5700703		POT, SLIDE, LINEAR, 100K, 1/3W, 30%
R14,33	1000915	U201R104B	POT, ROTARY TRIM, 100K, 1/2W, 30%
C4	1100606	G-0-X47-G-10-0	CAP, TANT, .47UF, 35V, 10%
C12	1100611	G-0-3X3-G-10-0	CAP, TANT, 3.3UF, 35V, 10%
C1,2	1100612	G-0-010-G-20-0	CAP, TANT, 10UF, 35V, 20%
S1,2,3,4,5,6	1903002	DC-51-03	SWITCH, ALT ACTION, 5P
P11	2200806	5142-015	CABLE, 16 PIN
P12,13	2200808	5142-004	CABLE, INTERCONNECTION, 16 PIN
PC BOARD, "SYNTHESIZER CONTROL"			
REFERENCE	ARP PART NUMBER	ARP/MFG NUMBER	DESCRIPTION
CR1-7	1200301	1N4148	DIODE, SIGNAL
CR8,9	1200201	1N4001	RECT, 50V, 1A
Q1	1302901	2N3904	TSTR, NPN, GP
Q2-7	1303001	2N3906	TSTR, PNP, GP
Z2	1400801	LM301AN	IC, OP AMPL
Z1	1401101	LM1458N	IC, OP AMPL, DUAL
Z3,4	1400601	CD4011AE	IC, GATE, 4 X 21 NAND
R22	1000901	U201R101B	POT, ROTARY TRIM, 100 OHM, 1/4W, 30%

R16	1000915	U201R104B	POT, ROTARY TRIM, 100K, 1/4W, 30%
R7	5700704		POT, SLIDE, LINEAR, 1K, 1/2W, 30%
R14,19,20,24,45	5700703		POT, SLIDE, LINEAR, 100K, 1/3W, 30%
R50,51,52	5700701		POT, SLIDE, AUDIO, 1M, 1/3W, 30%
C13	1100611	G-0-3X3-G-10-0	CAP, TANT, 3.3UF, 35V 10%
C1,9,10	1100612	G-0-010-G-20-0	CAP, TANT, 10UF, 35V, 20%
M1	7210501		VCF, 4075 MODULE
J12	2101302	16-511-10	SOCKET, DUAL-IN-LINE
PC BOARD, "STRING CONTROL"			

REFERENCE	ARP PART NUMBER	ARP/MFG NUMBER	DESCRIPTION
CR5-11	1200301	1N4148	DIODE, SIGNAL
CR12,13	1200201	1N4001	RECT, 50V, 1A
Q2	1302901	2N3904	TSTR, NPN, GP
Q1,3	1303001	2N3906	TSTR, PNP, GP
Z1,2	1404501	CD4016AE	IC, QUAD BILATERAL SWITCH
Z3	1401101	LM1458N	IC, OP AMPL, DUAL
Z4	1405401	CA339E	IC, QUAD COMPARATOR
R38	5700701		POT, SLIDE, AUDIO, 1M, 1/3W, 30%
R31	5700705		POT, SLIDE, LINEAR, 10K, 1/3W, 30%
C1,11,12,15,16	1100612	G-0-010-G-20-0	CAP, TANT, 10UF, 35V, 20%
C17,18	1100601	G-0-022-D-20-0	CAP, TANT, 22UF, 16V, 20%
S1-4	1903002	DC-51-03	SWITCH, ALT ACTION, SP
J13	2101302	16-511-10	SOCKET, DUAL-IN-LINE

PC BOARD, "POWER SUPPLY"

REFERENCE	ARP PART NUMBER	ARP/MFG NUMBER	DESCRIPTION
CR1,2,3,4,5	1200201	1N4001	RECT, 50V, 1A
Q3	1303001	2N3906	TSTR, PNP, GP
Z1	1401301	723DC	IC, VOLTAGE REGULATOR
Z2	1400801	LM301AN	IC, OP AMPL
R7,8	1000111	BW-20	RES, WW, TC, 0.68 OHM, 1W, 5%
R19,20	1000915	U201R104B	POT, ROTARY TRIM, 100K, 1/4W, 30%
C8	1100609	G-0-001-G-20-0	CAP, TANT, 1UF, 35V, 20%
C6,7	1100612	G-0-010-G-20-0	CAP, TANT, 10UF, 35V, 20%
C3	1101702	TAD250TG50	CAP, ELECT, 250UF, 50V, +50-10%
C1,2	1101301	TCW102V050N1R3P	CAP, ELECT, 1000UF, 50V, +75-10%
Q1	1304501	MJE1100	TSTR, NPN, PWR DARL
Q2	1304301	MJE1090	TSTR, PNP, PWR DARL
T1	5704401		TRANSFORMER, POWER
F1	1700404	MDV-1/2	FUSE, PIGTAIL, SLO-BLO 1/2A 250V

MISCELLANEOUS

REFERENCE	ARP PART NUMBER	ARP/MFG NUMBER	DESCRIPTION
	1201102	FLV 360	DIODE, LIGHT EMITTING